

Part No. 060334-10, Rev. J
March 2015

OmniSwitch 6900

Hardware Users Guide

Alcatel-Lucent 

www.alcatel-lucent.com

This user guide documents the OmniSwitch 6900 for AOS Release 7.3.4.

This user guide documents OmniSwitch 6900 hardware, including chassis and associated components. The specifications described in this guide are subject to change without notice.

Copyright© 2015 by Alcatel-Lucent. All rights reserved. This document may not be reproduced in whole or in part without the express written permission of Alcatel-Lucent.

OmniSwitch[®], Alcatel-Lucent[®] and the Alcatel-Lucent logo are registered trademarks of Alcatel-Lucent



26801 West Agoura Road
Calabasas, CA 91301
(818) 880-3500 FAX (818) 880-3505

Service & Support Contact Information

North America: 800-995-2696

Latin America: 877-919-9526

EMEA: +800 00200100 (Toll Free) or +1(650)385-2193

Asia Pacific: +65 6240 8484

Web: service.esd.alcatel-lucent.com

Email: esd.support@alcatel-lucent.com

Contents

	About This Guide	vii
	Supported Platforms	vii
	Who Should Read this Manual?	vii
	When Should I Read this Manual?	vii
	What is in this Manual?	viii
	What is Not in this Manual?	viii
	How is the Information Organized?	viii
	Documentation Roadmap	ix
	Related Documentation	xi
	Technical Support	xii
Chapter 1	OmniSwitch 6900	1-1
	OmniSwitch 6900 Availability Features	1-3
	Power Supply Redundancy	1-3
	Hot-Swapping	1-3
	Hardware Monitoring	1-4
Chapter 2	Chassis and Power Supplies	2-1
	OmniSwitch 6900 Chassis	2-2
	OS6900-X20 Front Panel	2-2
	OS6900-X20 Rear Panel	2-2
	OS6900-X40 Front Panel	2-3
	OS6900-X40 Rear Panel	2-3
	OS6900-X20 and OS6900-X40 Chassis Specifications	2-4
	OS6900-T20 Front Panel	2-6
	OS6900-T20 Rear Panel	2-6
	OS6900-T40 Front Panel	2-7
	OS6900-T40 Rear Panel	2-7
	OS6900-T20 and OS6900-T40 Chassis Specifications	2-8
	OS6900-Q32 Front Panel	2-10
	OS6900-Q32 Rear Panel	2-11
	OS6900-Q32 Chassis Specifications	2-12
	RJ45 Port Clearance	2-13
	Port Speeds Supported	2-13
	Chassis Status LEDs	2-14
	Network Port Status LEDs (OS6900-Q32 Switches)	2-15
	4X10G Splitter Cable LED Indicators	2-15

OmniSwitch 6900 Expansion Modules	2-16
OS-XNI-U4	2-16
OS-XNI-U12	2-16
OS-QNI-U3	2-17
OS-HNI-U6	2-17
OS-XNI-T8	2-18
OS-XNI-U12E	2-19
Plug-In Module Status LEDs	2-19
Mounting the Switch	2-20
General Mounting Recommendations	2-20
Airflow Recommendations	2-21
Front-to-Rear Airflow	2-22
Rear-to-Front Airflow	2-22
Airflow Mismatch	2-23
Blank Cover Panels	2-24
Rack-Mounting	2-25
Mid-Mounting the Chassis In the Rack	2-27
Standalone (Non-Rack Mounted) Installations	2-29
Plug-In Modules	2-30
Hot-Swapping Plug-In Modules	2-30
Hot-Swap Feature Guidelines	2-30
Hot-Swap Steps	2-30
Installing Plug-In Modules	2-31
Removing Plug-In Modules	2-33
Power Supplies	2-34
Airflow Direction	2-34
AC Power Supply	2-34
AC Power Supply LED States	2-35
DC Power Supply	2-36
DC Power Supply LED States	2-36
DC Power Supply Connections	2-37
Connecting a DC Cable Harness to the Chassis Power Supply	2-37
Connecting a DC Cable Harness to the DC Power Source	2-37
Installing Power Supplies	2-38
Removing Power Supplies	2-39
Chassis Fan Tray	2-40
Airflow Direction	2-40
Removing the Fan Tray	2-41
Installing the Fan Tray	2-42
Grounding the Chassis	2-43
Monitoring Chassis Components	2-44
Viewing Chassis Slot Information	2-44
Monitoring Chassis Temperature	2-44
Temperature Errors	2-45
Monitoring Fan Tray Status	2-45

Appendix A	Regulatory Compliance and Safety Information	A-1
	Declaration of Conformity: CE Mark	A-1
	Waste Electrical and Electronic Equipment (WEEE) Statement	A-1
	China RoHS: Hazardous Substance Table	A-2
	Standards Compliance	A-4
	FCC Class A, Part 15	A-5
	Canada Class A Statement	A-5
	JATE	A-5
	CISPR22 Class A warning	A-6
	Korea Emissions Statement	A-6
	VCCI	A-6
	Class A Warning for Taiwan and Other Chinese Markets	A-6
	Class 1M Laser Warning	A-6
	Network Cable Installation Warning	A-7
	Translated Safety Warnings	A-7
	Blank Panels Warning	A-7
	Electrical Storm Warning	A-7
	Installation Warning	A-7
	Invisible Laser Radiation Warning	A-8
	Operating Voltage Warning	A-8
	Power Disconnection Warning	A-8
	Proper Earthing Requirement Warning	A-9
	DC Power Supply Connection Warning	A-9
	Read Important Safety Information Warning	A-10
	Restricted Access Location Warning	A-10
	Wrist Strap Warning	A-10
	Instrucciones de seguridad en español	A-11
	Advertencia sobre el levantamiento del chasis	A-11
	Advertencia de las tapaderas en blanco	A-11
	Advertencia en caso de tormenta eléctrica	A-11
	Advertencia de instalación	A-11
	Advertencia de radiación láser invisible	A-11
	Advertencia de la batería de litio	A-11
	Advertencia sobre la tensión de operación	A-11
	Advertencia sobre la desconexión de la fuente	A-11
	Advertencia sobre una apropiada conexión a tierra	A-12
	Leer “información importante de seguridad”	A-12
	Advertencia de acceso restringido	A-12
	Advertencia de pulsera antiestática	A-12
	Clase de seguridad	A-12
	Advertencia de fuentes de poder	A-12

About This Guide

This *OmniSwitch 6900 Hardware Users Guide* describes OmniSwitch 6900 switch components and basic switch hardware procedures.

Supported Platforms

The information in this guide applies only to OmniSwitch 6900 switches.

Who Should Read this Manual?

The audience for this users guide is network administrators and IT support personnel who need to configure, maintain, and monitor switches and routers in a live network. However, anyone wishing to gain knowledge of OmniSwitch 6900 hardware will benefit from the material in this guide.

When Should I Read this Manual?

Read this guide as soon as you are ready to familiarize yourself with your switch hardware components. You should have already stepped through the first login procedures and read the brief hardware overviews in the *OmniSwitch 6900 Getting Started Guide*.

You should already be familiar with the very basics of the switch hardware, such as module LEDs and component installation procedures. This manual will help you understand your switch hardware in greater depth.

What is in this Manual?

This users guide includes the following hardware-related information:

- Descriptions of “Availability” features.
- Technical specifications for the chassis, power supplies, modules and fan tray.
- Power supply requirements.
- The dynamics of chassis airflow, including detailed illustrations of proper and improper airflow configurations.
- Hot-swapping power supplies, fan trays and modules.
- Installation and removal procedures for power supplies, fan trays and modules.
- Detailed illustrations and LED descriptions for chassis, network and power supply operability.
- Hardware-related Command Line Interface (CLI) commands.

What is Not in this Manual?

The descriptive and procedural information in this manual focuses on switch hardware. It includes information on some CLI commands that pertain directly to hardware configuration, but it is not intended as a software users guide. There are several OmniSwitch users guides that focus on switch software configuration. Consult those guides for detailed information and examples for configuring your switch software to operate in a live network environment. See [“Documentation Roadmap” on page -ix](#) and [“Related Documentation” on page -xi](#) for further information on software configuration guides available for your switch.

How is the Information Organized?

Each chapter in this guide focuses on a specific hardware component or a set of hardware components. All descriptive, technical specification, and procedural information for a hardware component can be found in the chapter dedicated to that component.

Documentation Roadmap

The OmniSwitch user documentation suite was designed to supply you with information at several critical junctures of the configuration process. The following section outlines a roadmap of the manuals that will help you at each stage of the configuration process. Under each stage, we point you to the manual or manuals that will be most helpful to you.

Stage 1: Using the Switch for the First Time

Pertinent Documentation: *OmniSwitch 6900 Getting Started Guide Release Notes*

A hard-copy *OmniSwitch 6900 Getting Started Guide* is included with your switch; this guide provides all the information you need to get your switch up and running the first time. It provides information on unpacking the switch, rack mounting the switch, installing NI modules, unlocking access control, setting the switch's IP address, and setting up a password. It also includes succinct overview information on fundamental aspects of the switch, such as hardware LEDs, the software directory structure, CLI conventions, and web-based management.

At this time you should also familiarize yourself with the Release Notes that accompanied your switch. This document includes important information on feature limitations that are not included in other user guides.

Stage 2: Gaining Familiarity with Basic Switch Functions

Pertinent Documentation: *OmniSwitch 6900 Hardware Users Guide*
OmniSwitch AOS Release 7 Switch Management Guide

Once you have your switch up and running, you will want to begin investigating basic aspects of its hardware and software. Information about switch hardware is provided in the *OmniSwitch 6900 Hardware Guide*. This guide provides specifications, illustrations, and descriptions of all hardware components. It also includes steps for common procedures, such as removing and installing switch components.

This guide is the primary users guide for the basic software features on a single switch. This guide contains information on the switch directory structure, basic file and directory utilities, switch access security, SNMP, and web-based management. It is recommended that you read this guide before connecting your switch to the network.

Stage 3: Integrating the Switch Into a Network

Pertinent Documentation: *OmniSwitch AOS Release 7 Network Configuration Guide*
OmniSwitch AOS Release 7 Advanced Routing Configuration Guide
OmniSwitch AOS Release 7 Data Center Switching Guide

When you are ready to connect your switch to the network, you will need to learn how the OmniSwitch implements fundamental software features, such as 802.1Q, VLANs, Spanning Tree, and network routing protocols. The *Network Configuration Guide* guide contains overview information, procedures, and examples on how standard networking technologies are configured on the OmniSwitch.

The *Advanced Routing Guide* includes configuration information for networks using advanced routing technologies (OSPF and BGP) and multicast routing protocols (DVMRP and PIM-SM).

The *Data Center Switching Guide* includes configuration information for data center networks using virtualization technologies (SPBM and UNP) and Data Center Bridging protocols (PFC, ETC, and DCBX).

Anytime

The *OmniSwitch CLI Reference Guide* contains comprehensive information on all CLI commands supported by the switch. This guide includes syntax, default, usage, example, related CLI command, and CLI-to-MIB variable mapping information for all CLI commands supported by the switch. This guide can be consulted anytime during the configuration process to find detailed and specific information on each CLI command.

Related Documentation

The following are the titles and descriptions of all the OmniSwitch 6900 user manuals:

- *OmniSwitch 6900 Getting Started Guide*

Describes the hardware and software procedures for getting an OmniSwitch up and running. Also provides information on fundamental aspects of OmniSwitch software architecture.
- *OmniSwitch 6900 Hardware Users Guide*

Complete technical specifications and procedures for all OmniSwitch 6900 chassis, power supplies, fans, and Network Interface (NI) modules.
- *OmniSwitch CLI Reference Guide*

Complete reference to all CLI commands supported on the OmniSwitch. Includes syntax definitions, default values, examples, usage guidelines and CLI-to-MIB variable mappings.
- *OmniSwitch AOS Release 7 Switch Management Guide*

Includes procedures for readying an individual switch for integration into a network. Topics include the software directory architecture, image rollback protections, authenticated switch access, managing switch files, system configuration, using SNMP, and using web management software (WebView).
- *OmniSwitch AOS Release 7 Network Configuration Guide*

Includes network configuration procedures and descriptive information on all the major software features and protocols included in the base software package. Chapters cover Layer 2 information (Ethernet and VLAN configuration), Layer 3 information (routing protocols, such as RIP and IPX), security options (authenticated VLANs), Quality of Service (QoS), link aggregation, and server load balancing.
- *OmniSwitch AOS Release 7 Advanced Routing Configuration Guide*

Includes network configuration procedures and descriptive information on all the software features and protocols included in the advanced routing software package. Chapters cover multicast routing (DVMRP and PIM-SM), Open Shortest Path First (OSPF), and Border Gateway Protocol (BGP).
- *OmniSwitch AOS Release 7 Data Center Switching Guide*

Includes and introduction to the OmniSwitch data center switching architecture as well as network configuration procedures and descriptive information on all the software features and protocols that support this architecture. Chapters cover Shortest Path Bridging MAC (SPBM), Data Center Bridging (DCB) protocols, Virtual Network Profile (vNP), and the Edge Virtual Bridging (EVB) protocol.
- *OmniSwitch Transceivers Guide*

Includes SFP and XFP transceiver specifications and product compatibility information.
- *Technical Tips, Field Notices*

Includes information published by Alcatel-Lucent's Customer Support group.
- *Release Notes*

Includes critical Open Problem Reports, feature exceptions, and other important information on the features supported in the current release and any limitations to their support.

Technical Support

An Alcatel-Lucent service agreement brings your company the assurance of 7x24 no-excuses technical support. You'll also receive regular software updates to maintain and maximize your Alcatel-Lucent product's features and functionality and on-site hardware replacement through our global network of highly qualified service delivery partners.

With 24-hour access to Alcatel-Lucent's Service and Support web page, you'll be able to view and update any case (open or closed) that you have reported to Alcatel-Lucent's technical support, open a new case or access helpful release notes, technical bulletins, and manuals.

Access additional information on Alcatel-Lucent's Service Programs:

Web: service.esd.alcatel-lucent.com

Phone: 1-800-995-2696

Email: esd.support@alcatel-lucent.com

1 OmniSwitch 6900

The OmniSwitch 6900 (OS6900) is a family of standalone aggregation switches that can also be installed as top-of-rack boxes in data centers. Refer to the information below for model number and component type.

Model Number	Description
OS6900-X20	Chassis with 20X10G SFP+ ports
OS6900-X40	Chassis with 40X10G SFP+ ports
OS6900-T20	Chassis with 20X10G 10GBase-T ports
OS6900-T40	Chassis with 40X10G 10GBase-T ports
OS6900-Q32	Chassis with 32X40G QSFP+ ports (with specified ports also supporting 40G or 4X10G)
OS-XNI-U4	Plug-in module with 4X10G SFP+ ports
OS-XNI-U12	Plug-in module with 12X10G SFP+ ports
OS-XNI-U12E	Enhanced plug-in module with 12X10G SFP+ or 12X2G/4G/8G Fibre Channel ports
OS-QNI-U3	Plug-in module with 3X40G QSFP+ ports
OS-HNI-U6	Plug-in module with 4X10G SFP+ and 2X40G QSFP+ ports
OS-XNI-T8	Plug-in module 8X10G 10GBase-T ports

OS6900 switches provide 1+1 redundant hot-swappable power supplies and a hot-swappable fan tray. All models include one RJ45 10/100/1000 EMP port, one console connector, one USB 2.0 high speed (480Mbits/sec) connector and support for front-to-rear or rear-to-front chassis airflow.

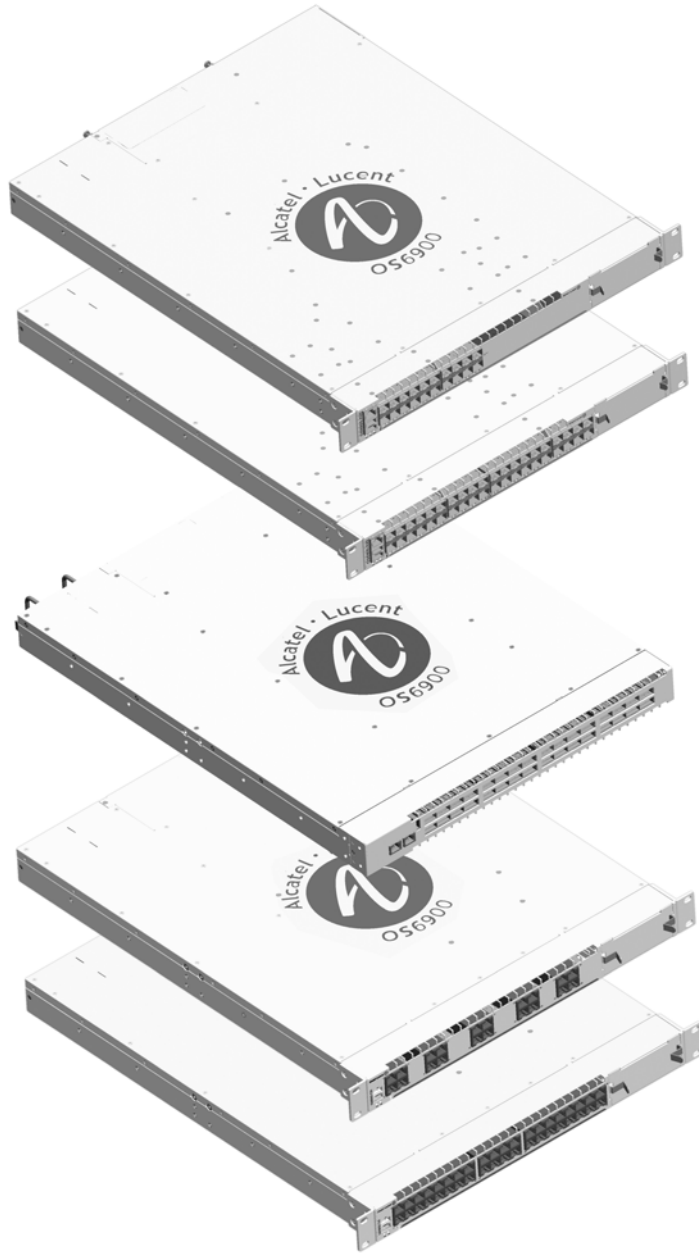

OmniSwitch 6900-X20

OmniSwitch 6900-X40

OmniSwitch 6900-Q32

OmniSwitch 6900-T20

OmniSwitch 6900-T40

OmniSwitch 6900 Availability Features

The switch provides a broad variety of availability features. Availability features are hardware and software-based safeguards that help prevent the loss of data flow in the unlikely event of a subsystem failure. In addition, some availability features allow users to maintain or replace hardware components without powering off the switch or interrupting switch operations. Combined, these features provide added resiliency and help ensure that the switch is consistently available for day-to-day network operations.

Hardware-related availability features include:

- [Power Supply Redundancy](#)
- [Hot-Swapping](#)
- [Hardware Monitoring](#)

Power Supply Redundancy

For information on power supply redundancy, refer to [Chapter 2, “Chassis and Power Supplies.”](#)

Hot-Swapping

Hot-swapping refers to the action of adding, removing, or replacing certain hardware components without powering off your switch and disrupting other components in the chassis. This feature greatly facilitates hardware upgrades and maintenance and also allows you to easily replace components in the unlikely event of hardware failure. The following hardware components can be hot-swapped:

- Power supplies
- Transceivers
- Fan tray
- Plug-in modules

Note. Hot-swapping guidelines apply to the various modules. In some cases a reboot is required. Refer to [“Hot-Swapping Plug-In Modules” on page 2-30](#) for detailed information on hot-swapping plug-in modules.

For information on adding and removing power supplies and plug-in modules, refer to [Chapter 2, “Chassis and Power Supplies.”](#)

Hardware Monitoring

Automatic Monitoring

Automatic monitoring refers to the switch's built-in sensors that automatically monitor operations. If an error is detected (e.g., over-threshold temperature), the switch immediately sends a trap to the user. The trap is displayed on the console in the form of a text error message.

LEDs

LEDs, which provide visual status information, are provided on the front and rear panels. LEDs are used to indicate conditions, such as hardware and software status, link integrity, data flow, etc. For detailed LED descriptions, refer to the corresponding hardware component section in the next chapter.

User-Driven Monitoring

User-driven hardware monitoring refers to CLI commands that are entered by the user in order to access the current status of hardware components. The user enters "show" commands that output information to the console. The Show commands for all the features are described in detail in the *OmniSwitch CLI Reference Guide*.

2 Chassis and Power Supplies

This chapter includes detailed information on the OmniSwitch 6900 chassis, as well as fan tray and power supply components. Topics include:

- Technical specifications, [page 2-4](#), [page 2-8](#) and [page 2-12](#).
- Switch mounting information, [page 2-20](#).
- Power supplies and power supply redundancy, [page 2-33](#).
- Temperature management, [page 2-44](#).
- Chassis fan tray on [page 2-45](#).
- Monitoring the chassis components via the Command Line Interface (CLI), [page 2-45](#)

OmniSwitch 6900 Chassis

OS6900-X20 Front Panel



Item	Description
A	Ethernet Management Port (EMP)
B	USB Port
C	Console Port
D	Status LEDs
E	20 Non-Combo 10G Ethernet Ports
F	Expansion Module Slot

OS6900-X20 Rear Panel

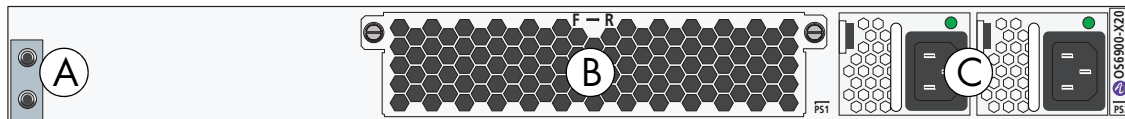

Item	Description
A	Chassis Grounding Lug
B	Fan Tray
C	Power Supply Bays (OS6900-BP-F AC power supplies shown)

OS6900-X40 Front Panel

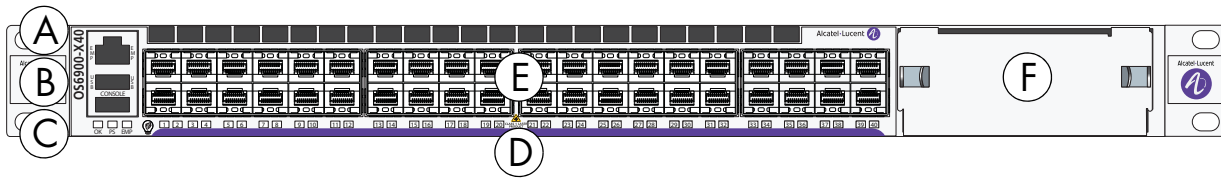

Item	Description
A	Ethernet Management Port (EMP)
B	USB Port
C	Console Port
D	Status LEDs
E	40 Non-Combo 10G Ethernet Ports
F	Expansion Module Slot

OS6900-X40 Rear Panel

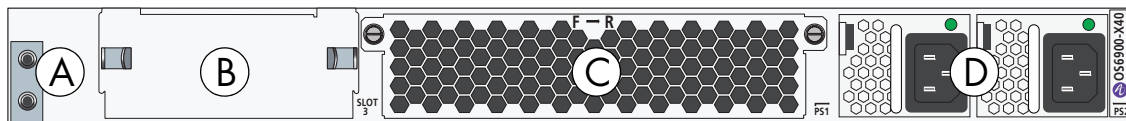

Item	Description
A	Chassis Grounding Lug
B	Expansion Module Slot
C	Fan Tray
D	Power Supply Bays

OS6900-X20 and OS6900-X40 Chassis Specifications

Note. For OS6900-T20 and OS6900-T40 chassis specifications, please refer to page [page 2-8](#). For OS6900-Q32 chassis specification, please refer to page [page 2-12](#).

Chassis Width (with brackets)	48.2 cm (19 inches)
Chassis Width (without brackets)	43.3 cm (17.05 inches)
Chassis Height	4.4 cm (1.73 inches or 1RU)
Overall Chassis Depth	55.9 cm (22 inches)
OS6900-X20 Chassis Weight (w/factory-installed fan tray only)	7.61 kg (16.8 lbs)
OS6900-X20 Chassis Weight (fully populated) ¹	10.21 kg (22.5 lbs)
OS6900-X40 Chassis Weight (w/factory-installed fan tray only)	7.78 kg (17.15 lbs)
OS6900-X40 Chassis Weight (fully populated) ¹	10.86 kg (23.95 lbs)
Power Supply Bays	2
OS6900-X20 Power Consumption (SFP+ transceivers) ²	181W**
OS6900-X40 Power Consumption (SFP+ transceivers) ²	242W**
Operating Temperature (Tmra)	
OS6900-X20-F (front-to-rear airflow)	0°C to 45°C (32°F to 113°F)
OS6900-X20-R (rear-to-front airflow)	0°C to 45°C (32°F to 113°F)
OS6900-X40-F (front-to-rear airflow)	0°C to 45°C (32°F to 113°F)
OS6900-X40-R (rear-to-front airflow)	0°C to 40°C (32°F to 104°F)
Storage Temperature	-10°C to +70°C (14°F to 158°F)
OS6900-X20 Temp Warning Threshold (front-to-rear airflow)	64°C (147°F)
OS6900-X20 Temp Warning Threshold (rear-to-front airflow)	58°C (136°F)
OS6900-X40 Temp Warning Threshold (front-to-rear airflow)	68°C (154°F)
OS6900-X40 Temp Warning Threshold (rear-to-front airflow)	60°C (140°F)
OS6900-X20 Temp Danger Threshold (front-to-rear airflow)	72°C (161°F)
OS6900-X20 Temp Danger Threshold (rear-to-front airflow)	70°C (158°F)
OS6900-X40 Temp Danger Threshold (front-to-rear airflow)	82°C (179°F)
OS6900-X40 Temp Danger Threshold (rear-to-front airflow)	70°C (158°F)
Operating Humidity	5% to 95% non-condensing
Storage Humidity	5% to 95% non-condensing

¹ Fully populated weights include fan tray, all installable power supplies and expansion modules. These figures do not include transceivers.

² Fully populated front panel (no expansion modules). *See individual expansion modules for power consumption information.*

***Note On Chassis Versus Ambient Temperatures.** Chassis temperature refers to the sensor reading of the internal switch temperature (threshold or danger). Ambient temperature refers to the approximate room temperature. The ambient temperature will typically be lower than the chassis temperature. Due to different airflow characteristics, chassis temperatures will vary by model.

OS6900-T20 Front Panel

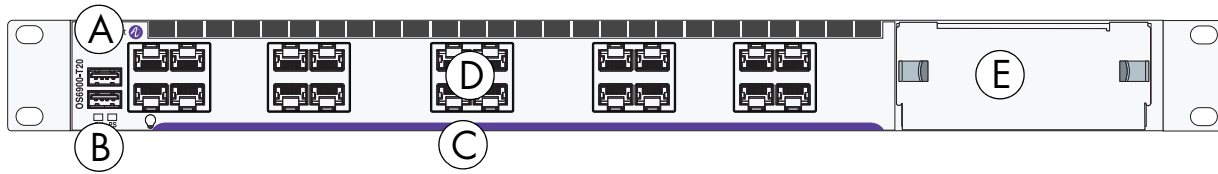

Item	Description
A	USB Port
B	Console Port
C	Status LEDs
D	20 Non-Combo 10GBase-T Ports
E	Expansion Module Slot

OS6900-T20 Rear Panel

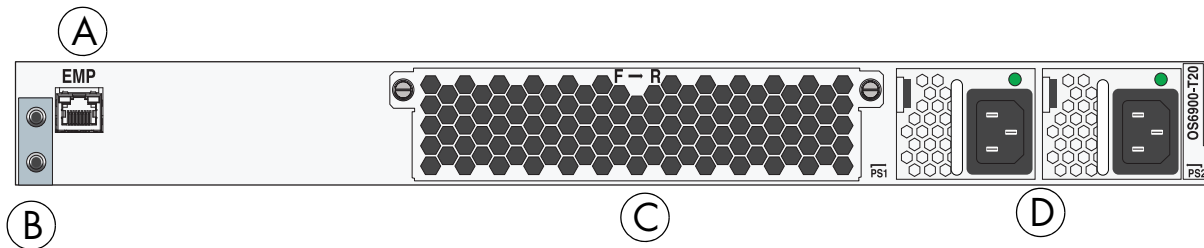

Item	Description
A	Ethernet Management Port (EMP)
B	Chassis Grounding Lug
C	Fan Tray
D	Power Supply Bays

OS6900-T40 Front Panel



Item	Description
A	USB Port
B	Console Port
C	Status LEDs
D	40 Non-Combo 10GBase-T Ports
E	Expansion Module Slot

OS6900-T40 Rear Panel

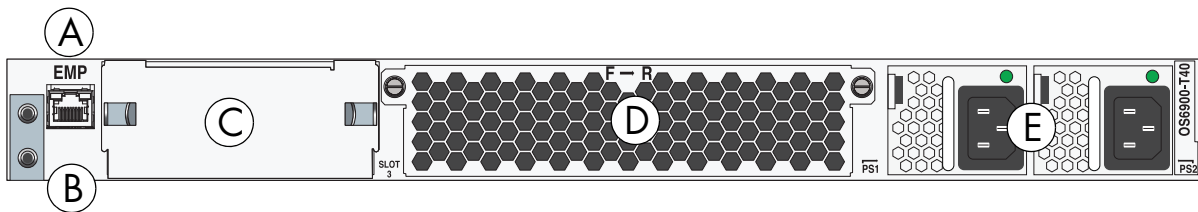

Item	Description
A	Ethernet Management Port (EMP)
B	Chassis Grounding Lug
C	Expansion Module Slot
D	Fan Tray
E	Power Supply Bays

OS6900-T20 and OS6900-T40 Chassis Specifications

Note. For OS6900-X20 and OS6900-X40 chassis specifications, please refer to page [page 2-4](#). For OS6900-Q32 chassis specification, please refer to page [page 2-12](#).

Chassis Width (with brackets)	48.2 cm (19 inches)
Chassis Width (without brackets)	43.3 cm (17.05 inches)
Chassis Height	4.4 cm (1.73 inches or 1RU)
Overall Chassis Depth	55.9 cm (22 inches)
OS6900-T20 Chassis Weight (w/factory-installed fan tray only)	7.61 kg (16.8 lbs)
OS6900-T20 Chassis Weight (fully populated) ¹	10.21 kg (22.5 lbs)
OS6900-T40 Chassis Weight (w/factory-installed fan tray only)	7.78 kg (17.15 lbs)
OS6900-T40 Chassis Weight (fully populated) ¹	10.86 kg (23.95 lbs)
Power Supply Bays	2
OS6900-T20 Power Consumption ²	206 Watts
OS6900-T40 Power Consumption ²	329 Watts
Operating Temperature (Tmra)	
OS6900-T20-F (front-to-rear airflow)	0°C to 45°C (32°F to 113°F)
OS6900-T20-R (rear-to-front airflow)	0°C to 45°C (32°F to 113°F)
OS6900-T40-F (front-to-rear airflow)	0°C to 40°C (32°F to 104°F)
OS6900-T40-R (rear-to-front airflow)	0°C to 45°C (32°F to 113°F)
Storage Temperature	-10°C to +70°C (14°F to 158°F)
OS6900-T20 Temp Warning Threshold (front-to-rear airflow)	67°C (152°F) chassis temp*
OS6900-T20 Temp Warning Threshold (rear-to-front airflow)	61°C (141°F) chassis temp*
OS6900-T40 Temp Warning Threshold (front-to-rear airflow)	77°C (170°F) chassis temp*
OS6900-T40 Temp Warning Threshold (rear-to-front airflow)	62°C (143°F) chassis temp*
OS6900-T20 Temp Danger Threshold (front-to-rear airflow)	77°C (170°F) chassis temp*
OS6900-T20 Temp Danger Threshold (rear-to-front airflow)	71°C (159°F) chassis temp*
OS6900-T40 Temp Danger Threshold (front-to-rear airflow)	89°C (192°F) chassis temp*
OS6900-T40 Temp Danger Threshold (rear-to-front airflow)	76°C (168°F) chassis temp*
Operating Humidity	5% to 95% non-condensing
Storage Humidity	5% to 95% non-condensing
Cable Supported	Cat 5e; Cat 6; Cat 6a; Cat 7
Cable Distances	55 meters Cat 5e and Cat 6 100 meters Cat 6a and Cat 7

¹ Fully populated weights include fan tray, all installable power supplies and expansion modules. These figures do not include transceivers.

² Fully populated front panel (no expansion modules). *See individual expansion modules for power consumption information.*

***Note On Chassis Versus Ambient Temperatures.** Chassis temperature refers to the sensor reading of the internal switch temperature (threshold or danger). Ambient temperature refers to the approximate room temperature. The ambient temperature will typically be lower than the chassis temperature. Due to different airflow characteristics, chassis temperatures will vary by model.

Note. OS6900-T20 and OS6900-T40 switches do not support Category 5 (Cat 5) cable

OS6900-Q32 Front Panel

OS6900-Q32: 40Gigabit Ethernet L3 fixed configuration chassis in a 1U form factor with 32 QSFP+ ports. All QSFP+ ports support 40G while specific ports (ports 1 - 6; 11 - 22 and 27 - 32) may operate as single 40G or 4X10G. (See front panel diagram and table below.)

System software detects when a direct-attach splitter cable is connected and allows each QSFP+ port to be configured as four (4) 10G SFP+ ports (allowing for a maximum number of 104 physical ports).

OmniSwitch 6900-Q32 switches support IEEE 1588.

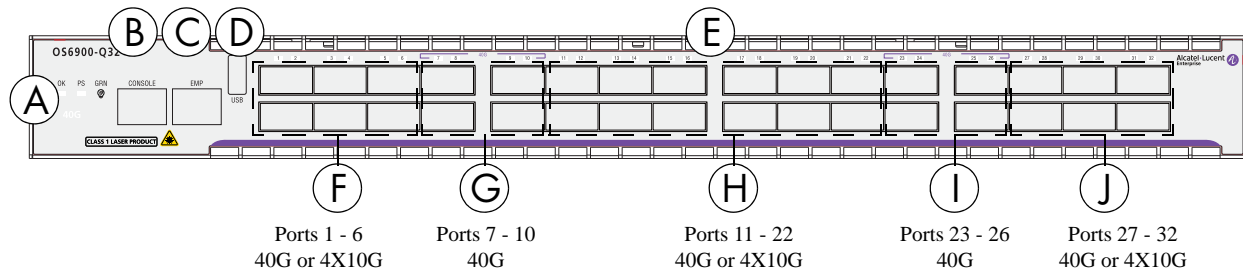

Item	Description
A	Status LEDs
B	Console Port (USB Form Factor - RS-232)
C	RJ45 10/100/1000 Ethernet Management Port (EMP)
D	USB Port (For use with Alcatel-Lucent OS-USB-FLASHDR USB flash drive)
E	Port Status LEDs*
F	QSFP+ ports 1 through 6: providing 40G or optional 4X10G splitter cable support
G	QSFP+ ports 7 through 10: providing 40G support only
H	QSFP+ ports 11 through 22: providing 40G or optional 4X10G splitter cable support
I	QSFP+ ports 23 through 26: providing 40G support only
J	QSFP+ ports 27 through 32: providing 40G or optional 4X10G splitter cable support

*Refer to [page 2-15](#) for detailed information on port LED behavior for OS6900-Q32 switches.

OS6900-Q32 Rear Panel

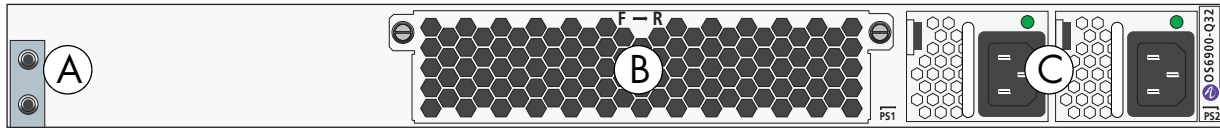

Item	Description
A	Chassis Grounding Lug
C	Fan Tray ¹
D	Power Supply Bays ²

¹ OS6900-Q32-specific fan trays must be used in the chassis. OS6900-Q32 fan trays are not interchangeable with other OmniSwitch 6900 products. Fan trays are offered with two airflow options: Front-to-Rear; Rear-to-Front.

² OS6900-Q32 switches use 450W removable power supplies. Each power supply includes a cooling fan. Airflow of installed power supplies must match the direction of the fan tray airflow. Options include AC supplies: OS-PS-450W-A (Front-to-Rear); OS-PS-450W-D (Rear-to-Front) and OS-PS-450W-D (Front-to-Rear).

OS6900-Q32 Chassis Specifications

Note. For OS6900-X20 and OS6900-X40 chassis specifications, refer to page [page 2-4](#). For OS6900-T20 and OS6900-T40 chassis specifications, refer to page [page 2-8](#).

Chassis Width	48.2 cm (19 inches)
Chassis Height	4.4 cm (1.73 inches or 1RU)
Overall Chassis Depth	55.9 cm (22 inches)
OS6900-Q32 Chassis Weight (w/factory-installed fan tray only)	7.78 kg (17.15 lb)
OS6900-Q32 Chassis Weight (fully populated) ¹	10.86 kg (23.95 lb)
Power Supply Bays	2
Maximum number of 40G ports	32
Maximum number of 10G ports (via QSFP+ to splitter cable)	104
Power Consumption ²	312W
Operating Temperature (Tmra)	
OS6900-Q32-F (front-to-rear airflow)	0°C to 45°C (32°F to 113°F)
OS6900-Q32-R (rear-to-front airflow)	0°C to 45°C (32°F to 113°F)
Storage Temperature	-10°C to 70°C (14°F to 158°F)
Operating Humidity	5% to 95% non-condensing
Storage Humidity	5% to 95% non-condensing

¹ Fully populated chassis includes fan tray, two power supplies, all expansion plug-in modules and no transceivers.

² Maximum power consumption under full L2 traffic load includes fan tray, two power supplies and transceivers; no expansion plug-in modules.

RJ45 Port Clearance

To ensure proper cable connector clearance on OS6900-T20 and OS6900-T40 switches and the OS-XNI-T8 expansion module, use RJ45 cables with the following maximum connector dimensions.

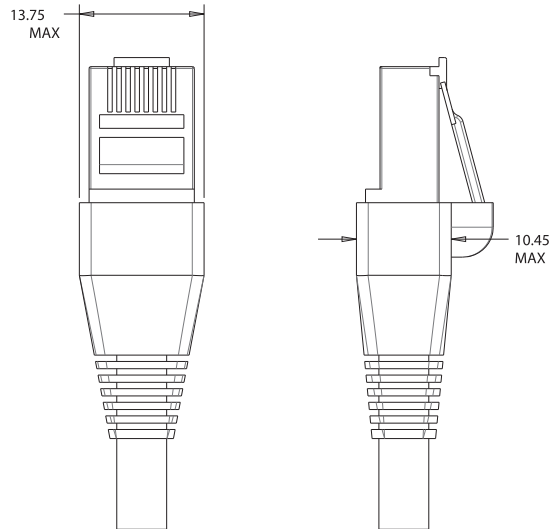

Port Speeds Supported

Model	Port Type	Port Speeds
OS6900-X20	SFP+	1G/10G
OS6900-X40	SFP+	1G/10G
OS-XNI-U4 Expansion Module	SFP+	1G/10G
OS-XNI-U12 Expansion Module	SFP+	1G/10G
OS-XNI-U12E Expansion Module	SFP+ Fibre Channel	1G/10G 2G/4G/8G
OS6900-T20	10GBase-T	100Mbps/1G/10G
OS6900-T40	10GBase-T	100Mbps/1G/10G
OS-XNI-T8 Expansion Module	10GBase-T	100Mbps/1G/10G

Chassis Status LEDs

The chassis provides a series of status LEDs located on the front panel. These LEDs offer basic status information for hardware operation and port link and activity status.

LED	State	Description
OK	Solid Green	Operational; if the switch is part of a Virtual Chassis (VC), it is operating in slave mode.
	Blinking Green	This switch is functioning as the master chassis within a VC.
	Blinking Amber	In transitional state (e.g. performing diagnostics or booting)
PS	Solid Green	Both power supplies are functional
	Solid Amber	One power supply is functional
OK and PS (Together)	Blinking Amber/Green	The switch is missing a fan tray, or a bootup has been attempted with a power supply and fan tray that have mismatched airflow directions. (The GRN power save LED also blinks green. See information below.)
	Blinking Amber	The switch is missing a fan tray, or a hot swap has been attempted with a power supply and fan tray that have mismatched airflow directions. The GRN power save LED (described below) also blinks green. For detailed information on airflow mismatch, see page 2-23 .
GRN 	Blinking Green	The GRN power save feature is not supported on the OmniSwitch 6900. For OS6900 switches, this LED is used (in addition to the OK and PS LEDs) to indicate an airflow direction error between the power supplies and fan tray, or a missing fan tray. For detailed information on airflow mismatch, see page 2-23 .
EMP (Not Present On OS6900-Q32 Switches)	Solid Green	EMP port link is up
	Blinking Green	EMP port link is active
Port LEDs*	Solid Green	Valid link
	Blinking Green	Port is active

*For OS6900-Q32 port status LEDs, refer to [page 2-15](#).

Network Port Status LEDs (OS6900-Q32 Switches)

Because OS6900-Q32 models provide splitter cable support on selected QSFP+ ports (see [page 2-12](#)), port LED behavior for this switch differs from other OS6900 models.

While it is important to note all details listed in the table below, general “at-a-glance” associations can be made when viewing LED colors. E.g., green typically indicates 40G (non-VC); yellow indicates 4X10G (non-VC) and blue indicates 40G or 4X10G in a VC configuration. More detailed port LED behavior for OS6900-Q32 switches is described below.

LED Display	Admin Status	Link Status	Transceiver	Traffic	VFL	40G/4X10G
Off	Down	Down	N/A	N/A	N/A	N/A
Off	Up	Down	No	N/A	N/A	N/A
Solid Green	Up	Up	Yes	No	No	40G
Solid Yellow	Up	Up	Yes	No	No	4X10G
Solid Blue	Up	Up	Yes	No	Yes	40G or 4X10G
Blinking Green	Up	Up	Yes	Yes	No	40G
Blinking Yellow	Up	Up	Yes	Yes	No	4X10G
Blinking Blue	Up	Up	Yes	Yes	Yes	40G or 4X10G
White*	N/A	N/A	Yes	N/A	N/A	4X10G

* Refer to [4X10G Splitter Cable LED Indicators](#) below.

4X10G Splitter Cable LED Indicators

When a port LED flashes white, a 4X10G splitter cable is installed. The white display is used as an indicator that separates the status for each of the four splitter cable sub ports. E.g., when the LED flashes white for a long duration, the status for sub port A displays next. When the LED subsequently flashes white for a shorter duration, the status for sub port B displays, etc. When the status for all four of the splitter cable’s sub ports has displayed, the cycle repeats:

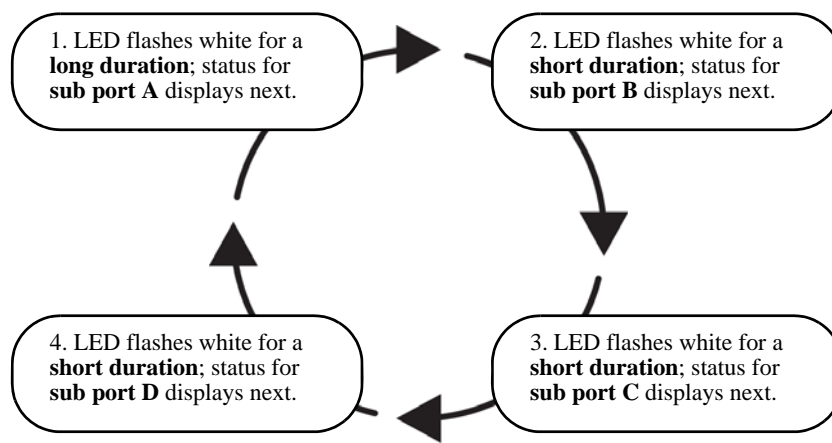

OmniSwitch 6900 Expansion Modules

OS-XNI-U4

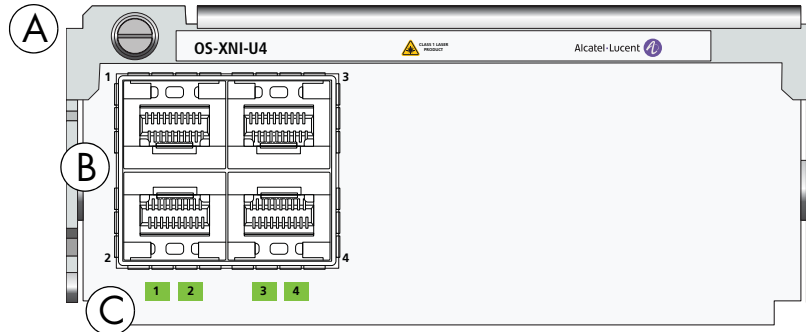

Item	Description
A	Lock Lever and Captive Screw
B	SFP+ Ports
C	Status LEDs
Power Consumption	19W (fully populated)

OS-XNI-U12

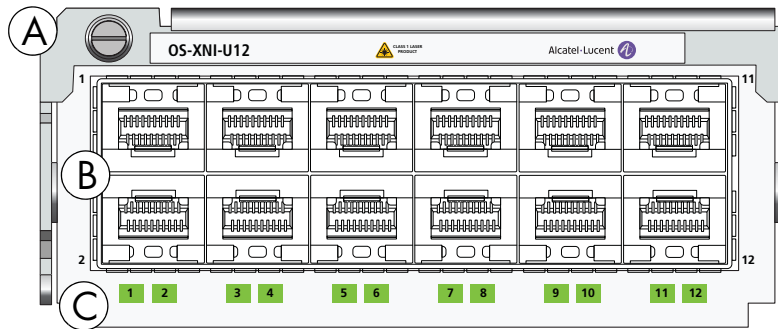

Item	Description
A	Lock Lever and Captive Screw
B	SFP+ Ports
C	Status LEDs
Power Consumption	44W (fully populated)

OS-QNI-U3

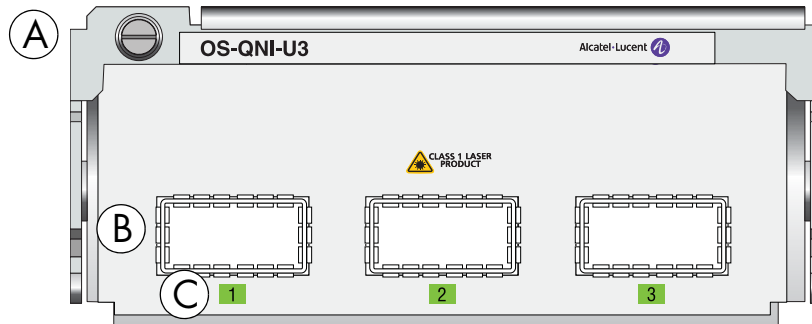

Item	Description
A	Lock Lever and Captive Screw
B	QSFP+ Ports
C	Status LEDs
Power Consumption	34W (fully populated)

OS-HNI-U6

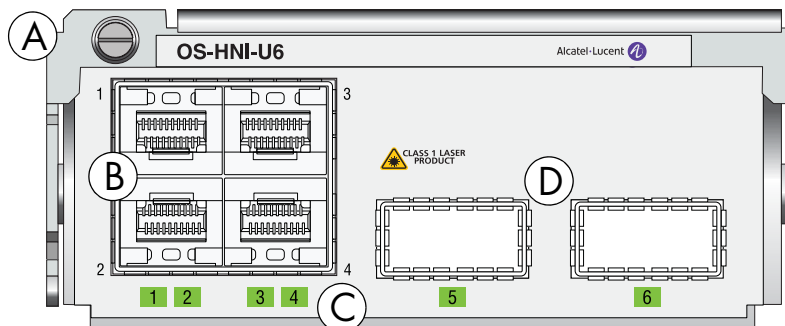

Item	Description
A	Lock Lever and Captive Screw
B	SFP+ Ports
C	Status LEDs
D	QSFP+ Ports
Power Consumption	37W (fully populated)

CAUTION - TRANSCEIVERS ARE CLASS 1M LASER RADIATION WHEN OPEN. DO NOT VIEW DIRECTLY WITH OPTICAL INSTRUMENTS.

OS-XNI-T8

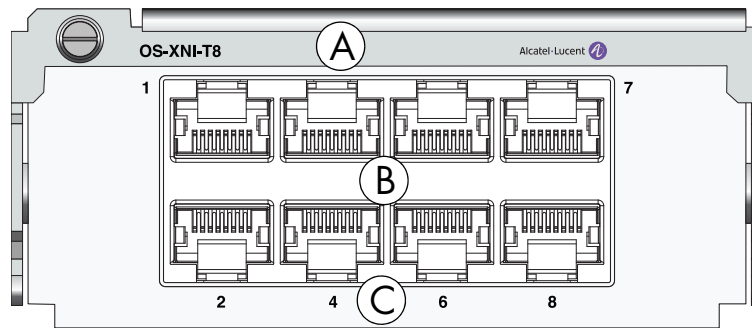

Item	Description
A	Lock Lever and Captive Screw
B	10GBase-T Ports
C	Status LEDs
Power Consumption	54W
Cable Supported	Cat 5e; Cat 6; Cat 6a; Cat 7
Cable Distances	55 meters Cat 5e and Cat 6 100 meters Cat 6a and Cat 7

Note. OS-XNI-T8 modules do not support Category 5 (Cat 5) cable.

OS-XNI-U12E

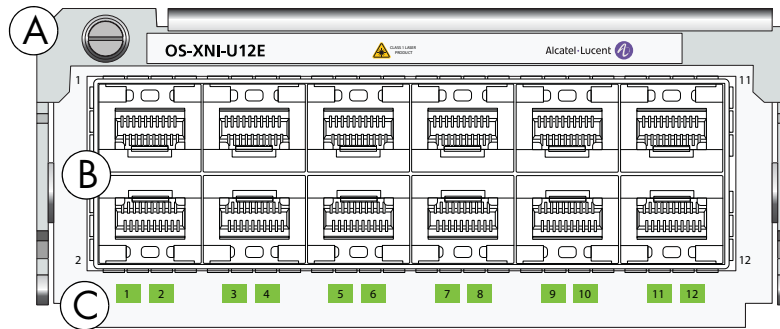

Item	Description
A	Lock Lever and Captive Screw
B	SFP+/FC Ports
C	Status LEDs
Power Consumption	31W (max. power, fully populated)

Note. OS-XNI-U12E modules support 12X10G SFP+ or 12X2G/4G/8G Fibre Channel connections. An Alcatel-Lucent Data Center License is required for Fibre Channel operation.

Plug-In Module Status LEDs

LED	State	Description
Port LEDs	Solid Green	Valid Link
	Blinking Green	Traffic/Activity

Mounting the Switch

General Mounting Recommendations

Elevated Operating Ambient Temperature. If installed in a closed or multi-rack assembly, the operating ambient temperature of the rack environment may be greater than the room's ambient temperature. Therefore, consideration should be given to the maximum rated ambient temperature (T_{mra}) specified on [page 2-4](#) (OS6900-X20 and OS6900-X40), [page 2-8](#) (OS6900-T20 and OS6900-T40) and [page 2-12](#) (OS6900-Q32).

Reduced Air Flow. Installation of the equipment in a rack should be such that the amount of air flow required for safe operation of the equipment is not compromised. Refer to [“Airflow Recommendations” on page 2-21](#) for more information.

Mechanical Loading. Mounting of the equipment in the rack should be such that a hazardous condition is not achieved due to uneven loading.

Circuit Overloading. Consideration should be given to the connection of the equipment to the supply circuit and the effect that overloading of circuits could have on overcurrent protection and supply wiring.

Reliable Earthing. Reliable earthing of rack-mounted equipment should be maintained. Particular attention should be given to supply connections other than direct connections to the branch (e.g., use of power strips).

Airflow Recommendations

To ensure proper airflow, be sure that your switch is placed in a well-ventilated area and provide minimum recommended clearance at the front, back and sides of the switch, as shown below. Restricted airflow can cause your switch to overheat, which can lead to switch failure. Refer to the following important guidelines regarding airflow:

- The switch supports both Front-to-Rear and Rear-to-Front airflow depending on the fan tray and power supplies installed. **The airflow direction of the power supplies and fan tray must be the same.**
- Running a mismatched fan tray or power supply will cause an error and trap to be displayed. Eventually the mismatched configuration will cause the chassis to reboot to avoid overheating.
- Follow the guidelines below regarding the minimum clearance requirements when mounting the chassis.

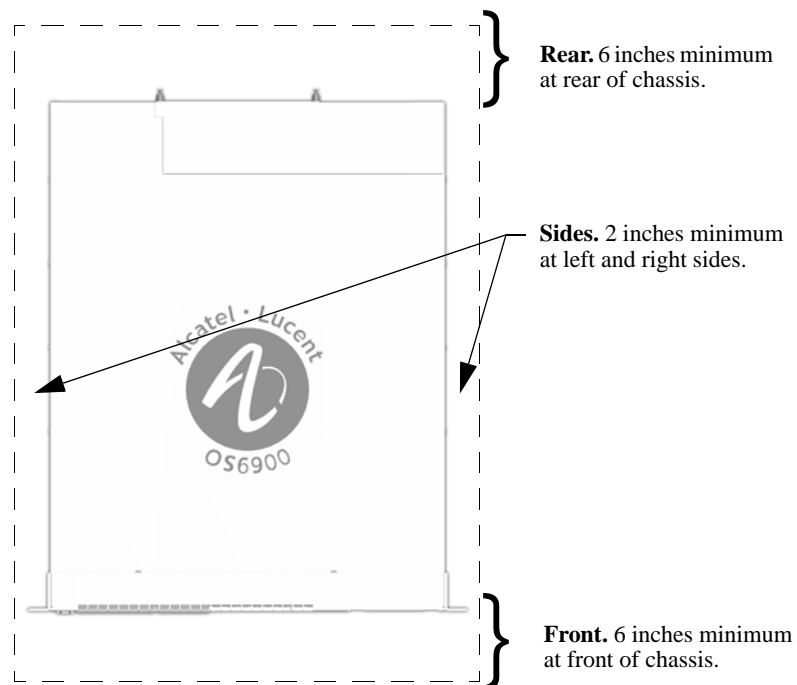

Chassis Top View

Note. Clearance is not required at the top and bottom of the chassis.

Front-to-Rear Airflow

The OmniSwitch 6900 fan tray and power supplies are located at the rear of the switch and draw air through the intake vents located at the top-front of the chassis. The air is directed straight through the chassis' module compartment and past the switch's circuit boards. Airflow is then exhausted through their vents.

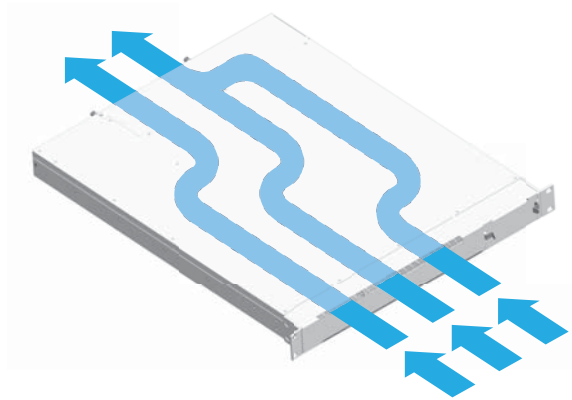

Chassis Airflow - Front to Rear

Rear-to-Front Airflow

The OmniSwitch 6900 fan tray and power supplies are located at the rear of the switch and draw air through their vents located at the rear of the chassis. The air is directed straight through the chassis' module compartment and past the switch's circuit boards. Airflow is then exhausted through the air vents on the top-front of the chassis.

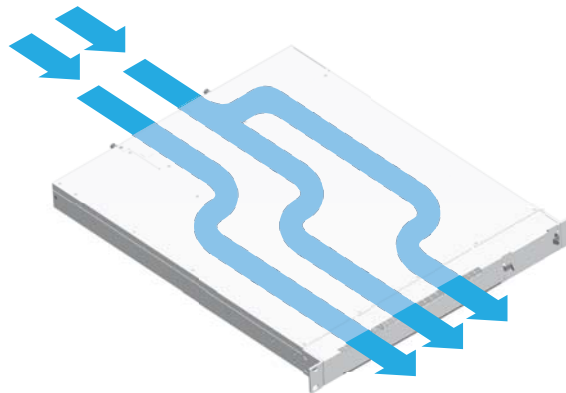

Chassis Airflow - Rear-to-Front

Airflow Mismatch

If an airflow mismatch is detected at bootup, OK and PS LEDs blink green/amber and the GRN LED blinks green (see [“Chassis Status LEDs” on page 2-14](#)), warnings display, and the switch continuously reboots until the issue is corrected.

If an airflow mismatch is detected after the switch has fully booted (e.g., when a fan tray or power supply is hot-inserted) OK and PS LEDs blink amber and the GRN LED blinks green (see [“Chassis Status LEDs” on page 2-14](#), warnings displayed, switch will reboot when it reaches temperature danger threshold.

Color Coding

To help users avoid mismatched fan trays and power supplies, rear-to-front components are marked with purple color coding. (Front-to-rear components use standard product colors.)

Blank Cover Panels

Blank cover panels are provided with your switch and are used to cover empty slots. These cover panels play an important role in chassis airflow and temperature management. If your switch is not fully populated and blank cover panels are not installed over empty slot locations, airflow is affected.

When blank cover panels are missing, air does not take the direct route from the air intake vents, through the chassis module compartment, and out through the fan's exhaust vent as intended. Instead, a portion of the airflow is allowed to escape through other openings in the chassis. As a result, normal airflow is disrupted and an extra task is placed on the fan tray to cool the chassis.

Cover panels also provide protection for module processor boards and other sensitive internal switch components by closing off a chassis that is not fully populated.

Note. Because they regulate airflow and help protect internal chassis components, blank cover panels should be installed over empty module slots and power supply bays at all times.

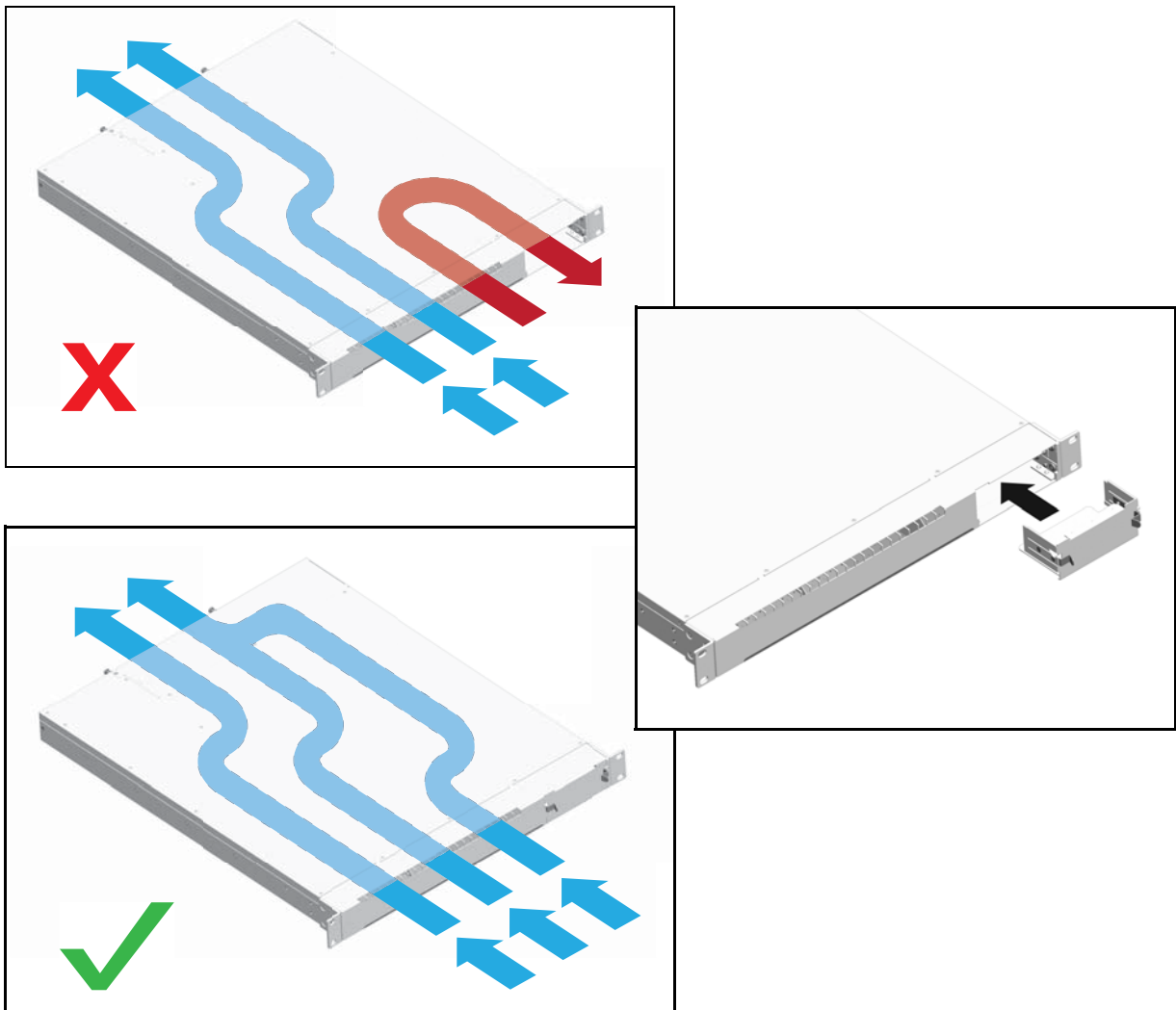

Blank Panels and Chassis Airflow

Rack-Mounting

Refer to the following important guidelines before installing the chassis in a rack:

- Two people are required to rack mount the switch: One person to lift the chassis into position and one person to secure the chassis to the rack using the rack mount screws.
- The chassis has rack-mount flanges that support standard 19-inch rack mount installations.
- Alcatel-Lucent does not provide rack-mount screws. Use the screws supplied by the rack vendor.
- To prevent a rack from becoming top heavy, it is recommended that you install the switch at the bottom of the rack whenever possible.
- If you are installing the switch in a relay rack, be sure to install and secure the rack per rack manufacturer's specifications.

To rack mount the switch, follow the steps below.

Note. Because of the overall chassis depth, additional support braces are used to support the rear of the chassis and prevent sagging in the rack. These braces are required for all rack-mount installations.

- 1 Mark the holes on the rack where the chassis is to be installed.
- 2 Attach two slot rails to the left and right side of the chassis.

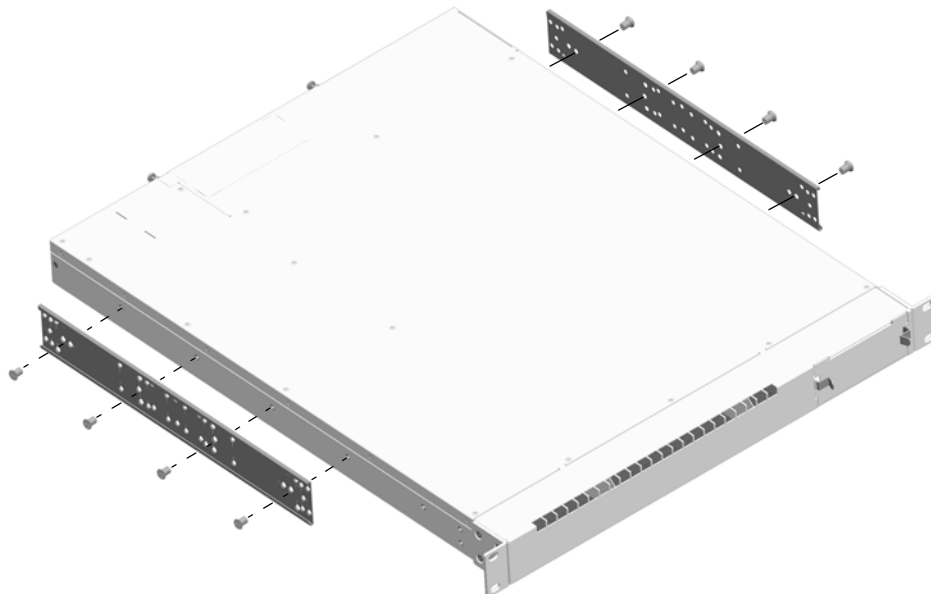

- 3 One person should lift and position the chassis until the rack-mount flanges are flush with the rack post.
- 4 Align the holes in the flanges with the rack holes marked in step 1.

- 5 Once the holes are aligned, the second person should insert a screw through the *bottom hole on each flange*. Tighten both screws until they are secure.

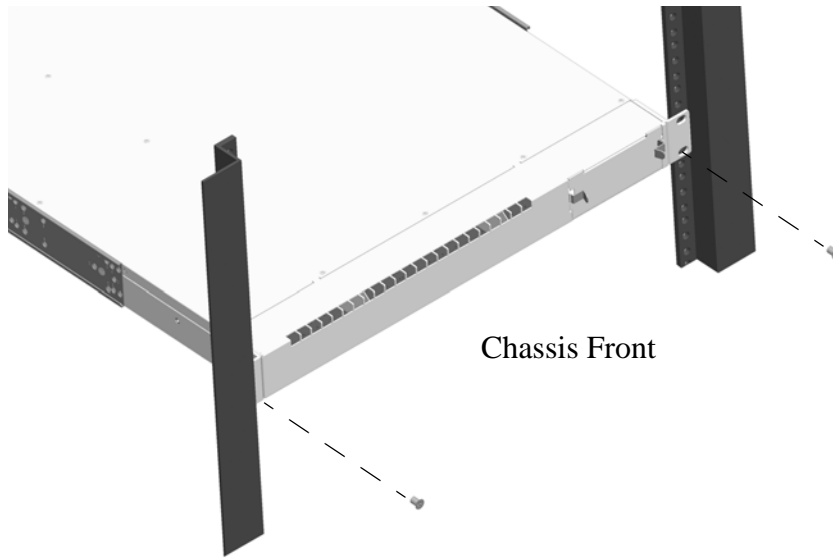

- 6 From the back of the chassis and with the flanges facing out, insert the slide-in braces into the slot rails until they meet the rack posts.

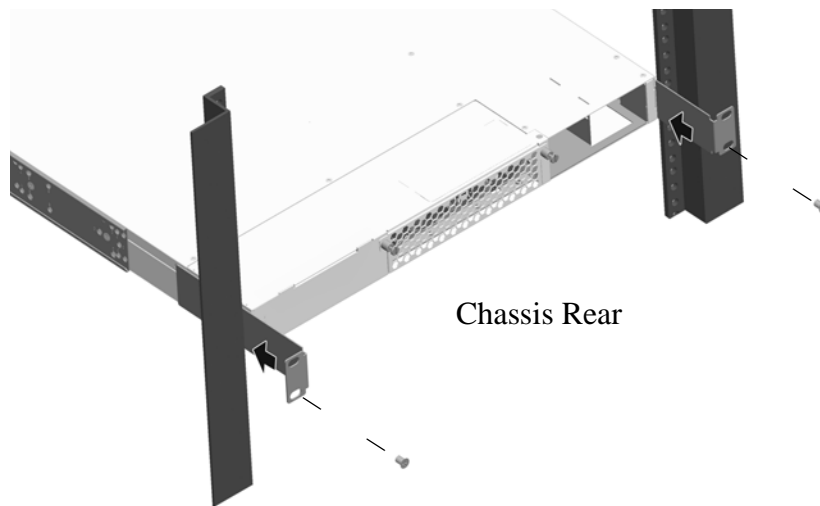

- 7 The chassis installation should be level. Be sure that the holes and flanges of the slide-in brace are aligned with the corresponding holes at the front of the rack.
- 8 Once the flanges are aligned, install the remaining screws in all four flanges. Be sure that all screws are securely tightened.

Note. Never rack mount OS6900 switches using only the front-installed rack mount flanges. Due to the chassis overall depth, OS6900 switches must be mounted using additional support braces (available from Alcatel-Lucent) or by attaching flanges to the mid portion of the chassis (using the threaded holes provided). Failure to properly mount the switch may result in the chassis sagging in the rack or damage to the switch and its components. Refer to the following sections for more information.

Mid-Mounting the Chassis In the Rack

The switch may also be installed in the rack using mid-mount flanges. To mid-mount the switch in a rack, follow the steps below.

- 1 If needed, remove the mounting flanges from the front of the chassis and the slot rails from the side of the chassis by unscrewing the attachment screws.
- 2 Reinstall the mounting flanges at the mid point of the chassis using the threaded holes, as shown in the diagram below.

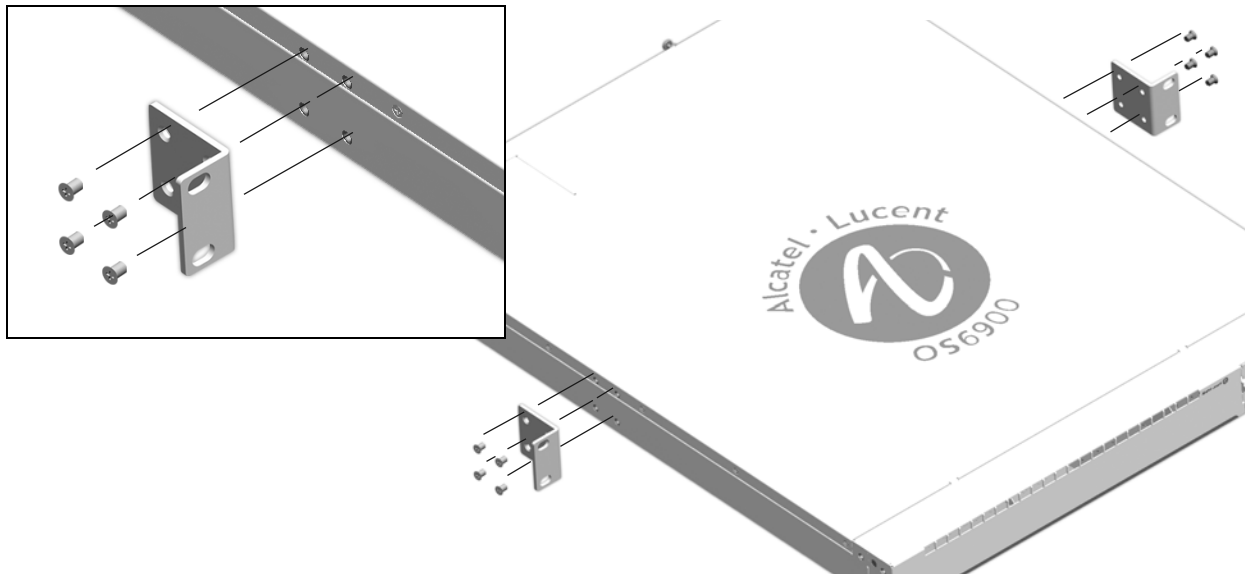

- 3 Mark the holes on the rack where the chassis is to be installed.
- 4 One person should lift and position the chassis until the mid-mount flanges are flush with the rack post.
- 5 Align the holes in the flanges with the rack holes marked in step 3.

- 6 Once the holes are aligned, the second person should insert a screw through the bottom hole on each flange. Tighten both screws until they are secure.

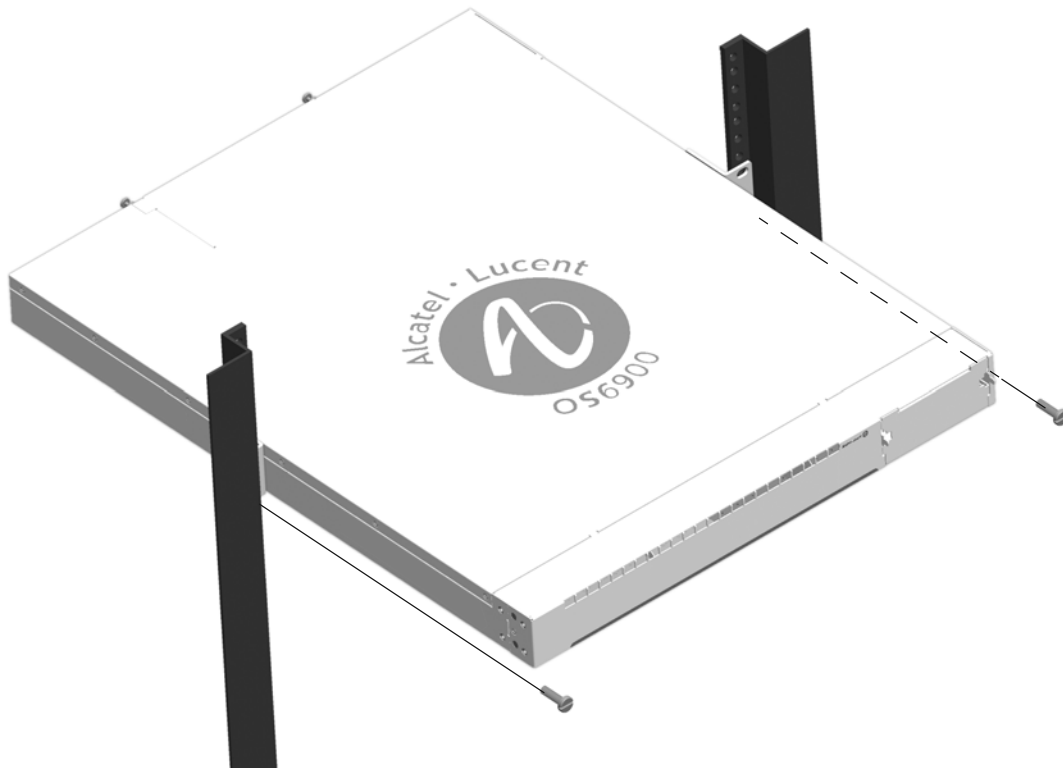

- 7 Once the flanges are aligned, install the remaining screws. Be sure that all screws are securely tightened.

Standalone (Non-Rack Mounted) Installations

The chassis can also be placed unmounted on a stable, flat surface as a standalone unit. Be sure that the surface can accommodate the full, populated weight of all switches being installed. Approximate chassis weights are provided on [page 2-4](#) (OS6900-X20 and OS6900-X40) and [page 2-8](#) (OS6900-T20 and OS6900-T40).

For a standalone unit, use two or more people to move and position the unpopulated chassis upright on the surface where it is to be installed. Be sure that adequate clearance has been provided for chassis airflow and that you have placed the chassis within reach of all required AC outlets. For recommended airflow allowances, refer to [page 2-21](#).

Note. Chassis must be placed “right side up.” Never attempt to operate a switch while it is placed on its top or side.

Plug-In Modules

Hot-Swapping Plug-In Modules

Hot-swapping guidelines apply to the various plug-in modules. In some cases a reboot is required. Refer to the table below for the supported hot-swap scenarios for each plug-in module.

Existing Expansion Slot	Hot-Swap/Hot-Insert Compatibility
Empty	OS-XNI-U12, OS-XNI-U4
OS-XNI-U4	OS-XNI-U12, OS-XNI-U4
OS-XNI-U12	OS-XNI-U12, OS-XNI-U4
OS-XNI-U12E	OS-XNI-U12E
OS-HNI-U6	OS-HNI-U6
OS-QNI-U3	OS-QNI-U3
OS-XNI-T8	OS-XNI-T8

Note. All other scenarios require a reboot.

Hot-Swap Feature Guidelines

For OS6900-X40 switches, wait for first module to become fully operational before adding the second module.

Hot-Swap Steps

- 1 Disconnect all cables from transceivers on module to be hot-swapped.
- 2 Extract all transceivers from module to be hot-swapped.
- 3 Extract the module from the chassis and wait approximately 30 seconds before inserting replacement.
- 4 Insert replacement module of same type.
- 5 Wait for a ChassisSupervisor niMgr notification similar to the following to display on the console:

```
+++ Expansion module 2 ready!
```
- 6 Re-insert all transceivers into new module.
- 7 Re-connect all cables to transceivers.

Installing Plug-In Modules

Note. When installing plug-in modules, the transceivers must not be installed. Otherwise, the transceivers will interfere with the module's lock lever.

- 1 With the lock lever in the open position, insert the module into the chassis card guides and slide the module straight back.

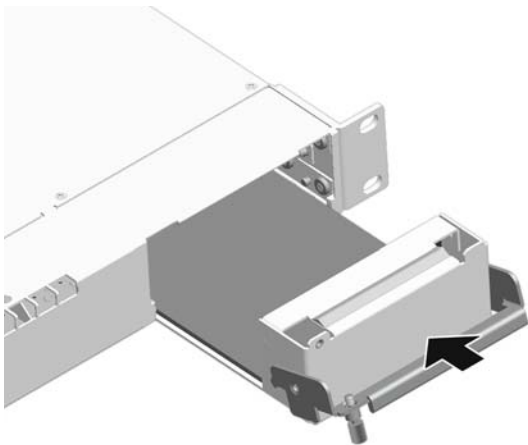

- 2 When the bottom portion of the lever meets the chassis, be sure that the catches grab the chassis sheet metal, then push the lever up and back as shown. This will fully seat the module in the chassis backplane.

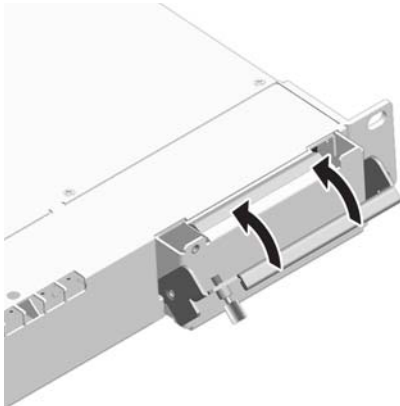

- 3 Tighten the captive screw to complete the installation.

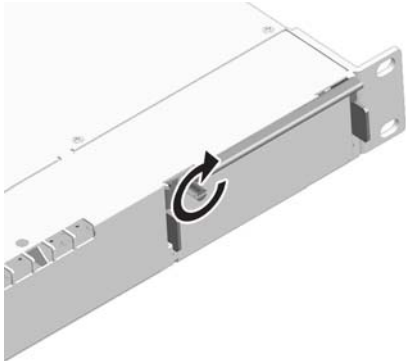

Removing Plug-In Modules

- 1 Loosen the captive screw.

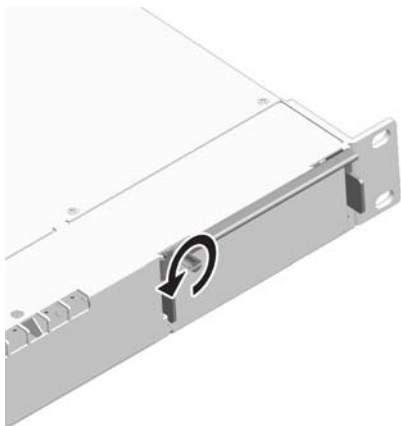

- 2 Pull down on the lock lever to release the plug-in module from the chassis backplane.

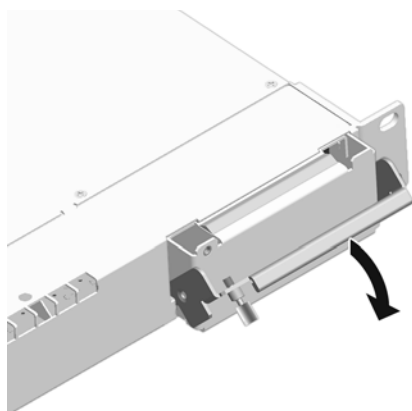

- 3 Using the lock lever as a handle, pull the plug-in module straight back and out of the chassis.

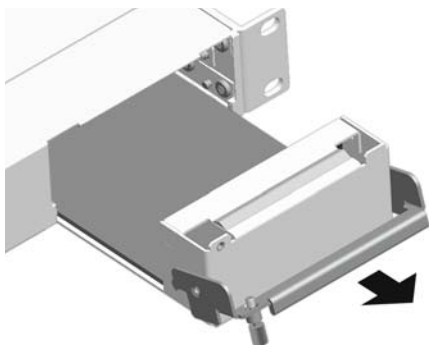

Power Supplies

OmniSwitch 6900 power supplies are located at the rear of the switch chassis. Refer to [page 2-2](#) and [page 2-3](#) for more information on component location. Two slots are provided. If a second power supply is installed, it will assume a standby role.

Please note that the OS6900 does not provide an on/off switch. Connecting an installed power supply to a power source will boot the switch. Likewise, disconnecting all installed power supplies from a power source will power off the switch.

Airflow Direction

Power supplies are available in front-to-rear airflow or rear-to-front airflow models. Fan trays are also direction-specific (front-to-rear or rear-to-front). When installing power supplies, they must match the airflow direction of the fan tray. (See [“Airflow Mismatch”](#) on [page 2-23](#) for more information.)

AC Power Supply

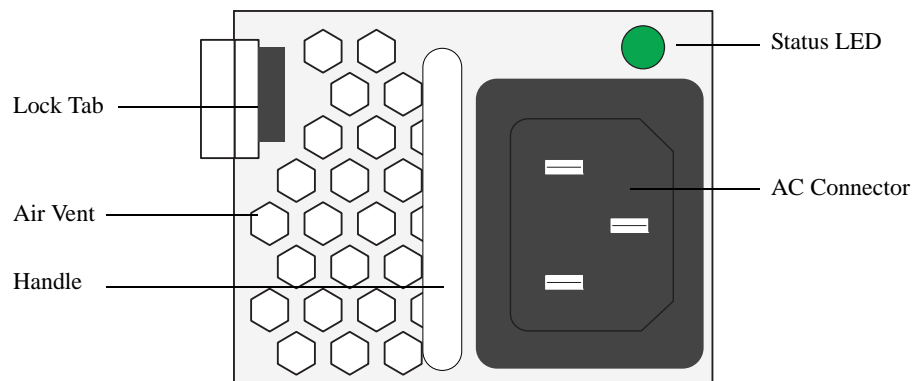

AC Power Supply Front Panel

Model (OS-PS-450W-A)	OS6900-BP-F (YM-2451C), Front-to-Rear OS6900-BP-R (YM-2451F), Rear-to-Front (Purple Coloring)
Product Compatibility	OmniSwitch 6900
Input Voltage Range	90-132VAC; 180-264VAC
Nominal Voltage	115 VAC; 230 VAC
Operating Frequency	47-63 Hz
Max. Power	450W
Input Current	8A (90-132V); 4A (180-264V)
Output Rating	2A min to 37A max @ +12V; 0A min to 3A max @ +5VSB
Ambient Temperature	Non-Operating -40C to 70C
Humidity (Operating)	95%, non-condensing
Humidity (Non-Operating)	95%, non-condensing
Airflow	This power supply is available in either a front-to-rear or rear-to-front model.

AC Power Supply LED States

LED State	Description
Solid Green	The power supply is operating normally and providing power to the chassis
Flashing Green	The power supply is on standby and can provide power to the chassis if power supply failover should occur
Flashing Red	No AC power is being provided to this power supply
Flashing Green/Red	Power supply warning
Solid Red	Power supply failure
Off	No AC power is being provided to any power supply installed in the chassis; all power supplies are effectively off

DC Power Supply

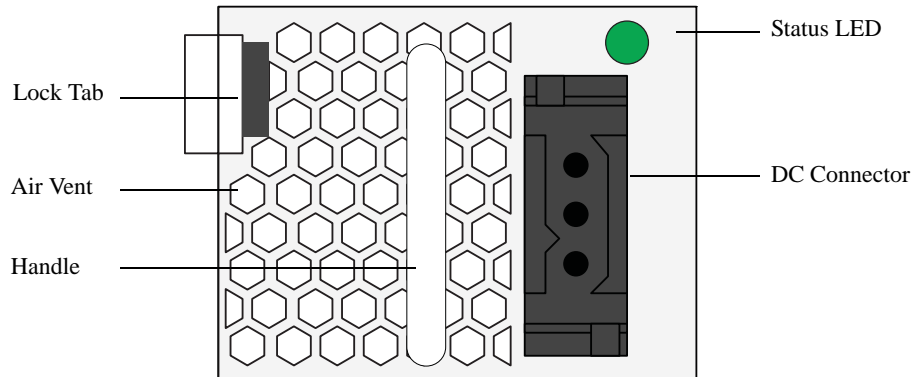

DC Power Supply Front Panel

Model (OS-PS-450W-D)	OS6900-BPD-F (YM-2451D), Front-to-Rear OS6900-BPD-R (YM-2451P), Rear-to-Front (Purple Coloring)
Product Compatibility	OmniSwitch 6900
Input Voltage Range	-36V (min.); -48V (nominal); -72V (max.); -75V (peak)
Input Current	14A (40VDC), 9A (60VDC), nominal is 11.5A (48VDC)
Output Rating	2A min to 36.25A max @ +12V; 0A min to 3A max @ +5VSB
Output Power	450 Watts
Ambient Temperature	Non-Operating -40C to 70C
Humidity (Operating)	95%, non-condensing
Airflow	This power supply is available in either a front-to-rear or rear-to-front model.

DC Power Supply LED States

LED State	Description
Solid Blue	The power supply is operating normally and providing power to the chassis
Flashing Blue	The power supply is on standby and can provide power to the chassis if power supply failover should occur
Flashing Red	No DC power is being provided to this power supply
Flashing Blue/Red	Power supply warning
Solid Red	Power supply failure
Off	No DC power is being provided to any power supply installed in the chassis; all power supplies are effectively off

DC Power Supply Connections

Connecting a DC Cable Harness to the Chassis Power Supply

When plugging in the cable, insert the connector end of the cable harness into the power supply connector until it clicks firmly into place. This is an indication that the connector is secure and properly seated.

Connecting a DC Cable Harness to the DC Power Source

Safety Guidelines

Before connecting the DC cable to a power source, be sure to follow these important guidelines:

- Review all manufacturer specifications and requirements for DC power supplies and cables before connecting.
- Connect to a reliably ground -48VDC Selv source.
- The branch circuit overcurrent protection must be rated 15A.
- Use 12AWG copper conductors.
- A readily accessible disconnect device that is suitably approved and rated shall be incorporated in the field wiring.
- The power source must be installed in a restricted access location.

Primary Ground Information

The product has been designed to be installed in a Common Bonding Network (CBN). The pin of the Green/Yellow ground lead in the three pin cable connector is connected to the ground connector on the DC power supply, which is identified by a Grounding symbol. The Green/Yellow lead wire at the other end of the cable must be connected to a proper earth ground point.

The rear chassis has two ground holes. To properly ground the equipment, connect a Panduit Corporation UL listed Lug, (Part number LCD8-10A-L) to the two threaded holes located at the rear, insert two 10-32, 3/8" threaded pan head screws into these ground holes, and connect them to a proper earth ground point, using protective earthing conductor wire and 8AWG copper conductors.

Connection Details

Connect the power supply using the supplied DC cable. The cable consists of three 12AWG wires (Green/Yellow, Black, Red).

One end of the cable has a three pin connector in a plastic housing that is inserted into a three pin input connector on the power supply. The other end of the cable is connected to a fuse panel or other source of -48VDC power.

Observe proper polarity when connecting to a fuse panel. The cable wire leads must be connected as follows:

- Green/yellow - ground
- Black - return
- Red - -48VDC

Note. The battery return conductor is an Isolated DC Return (DC-1).

Installing Power Supplies

- 1 Orient the power supply so that the power cord socket is situated at the right of the power supply. Also, for the power supply to seat properly, make sure that the handle is in the vertical position as shown.

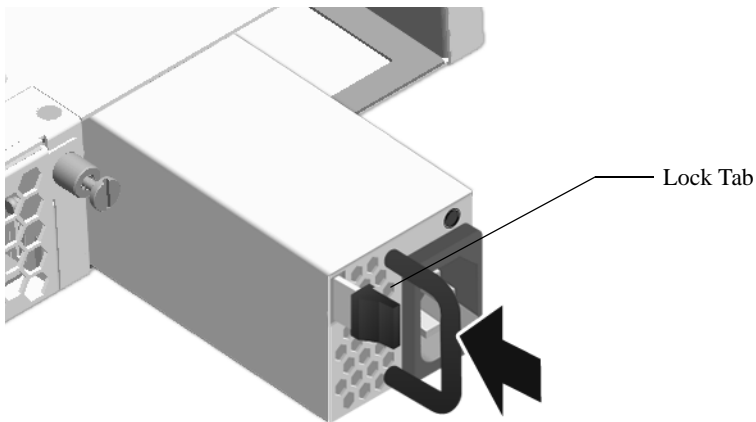

- 2 Slide the power supply back until it is securely seated in the chassis backplane. When the connector is fully seated, the lock tab will click and hold the power supply in place.
- 3 Plug the power cord (provided) into the power supply's socket.

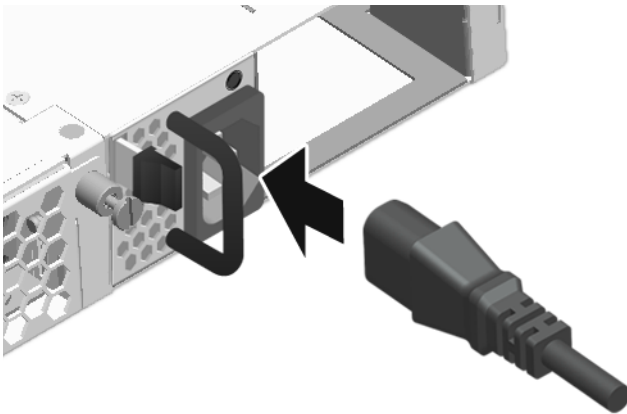

Note. The chassis *does not* provide an on/off switch. Connecting a the power supplies to a power source will boot the switch.

Removing Power Supplies

- 1 When removing a power supply, first disconnect the power cord from the power source. Once the power cord is disconnected, pull the power cord out of the power supply housing.

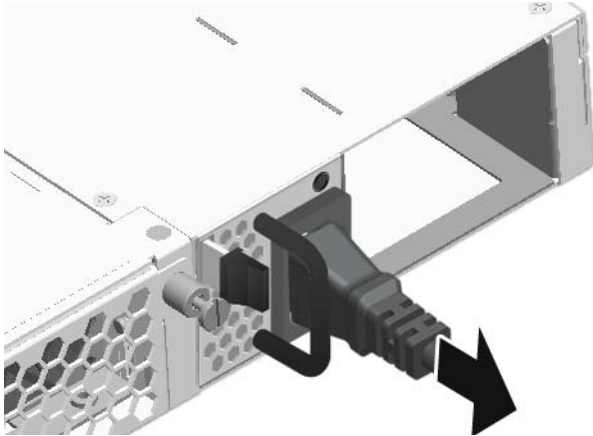

- 2 Pressing the lock tab toward the right, as shown, will free the power supply from the chassis. While pressing the lock tab, pull the power supply straight back and out of the chassis slot.

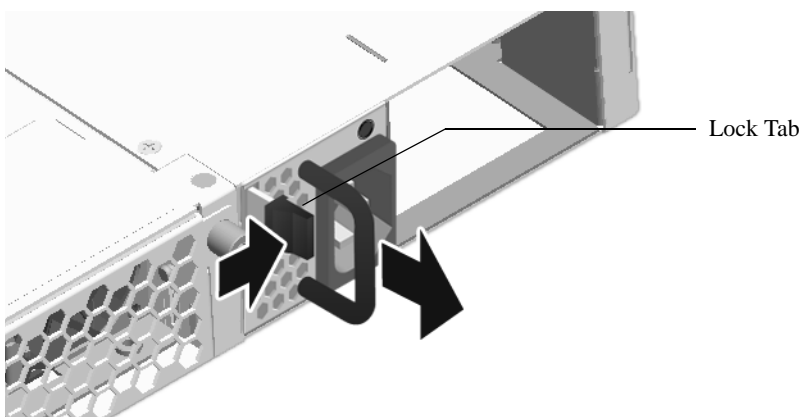

Note. If you are not replacing the power supply, be sure to install a blank cover panel over the empty power supply bay.

Chassis Fan Tray

The OmniSwitch 6900 chassis houses a single fan tray with four independently-operating fan. The fans are the main temperature control components for the switch, providing cooling airflow for all chassis components. This airflow is a crucial factor in the switch's overall operability. Refer to [“Airflow Recommendations” on page 2-21](#) for more information.

Important. The fan tray is a required component. Never attempt to operate the switch without a fan tray installed

Airflow Direction

The fan tray is available in front-to-rear airflow or rear-to-front airflow models. Power supplies are also direction-specific (front-to-rear or rear-to-front). When installing a fan tray in the chassis, it must match the airflow direction of the power supplies. (See [“Airflow Mismatch” on page 2-23](#) for more information.)

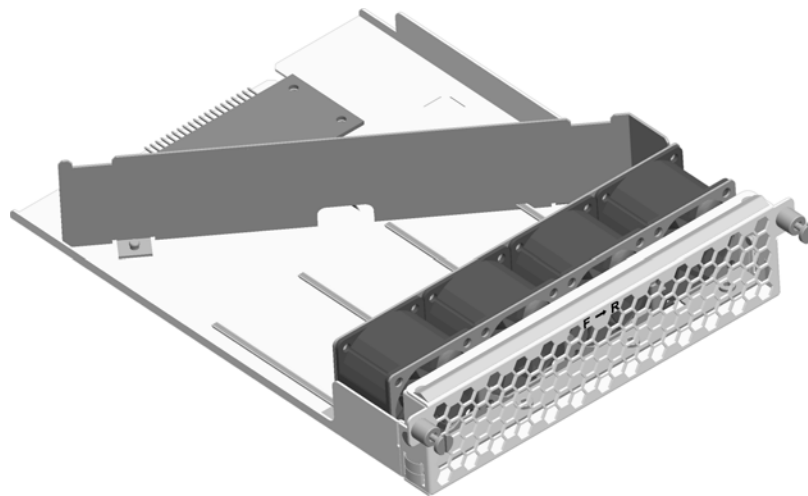

OmniSwitch 6900 Fan Tray

Model	OS6900-FT-F, Front-to-Rear OS6900-FT-R, Rear-to-Front
Product Compatibility	OmniSwitch 6900
Airflow	Airflow direction is indicated by an F ->R or R ->F label and purple coloring for rear-to-front.

Removing the Fan Tray

- 1 Begin by loosening the two captive screws located at the left and right sides of the tray's front panel.

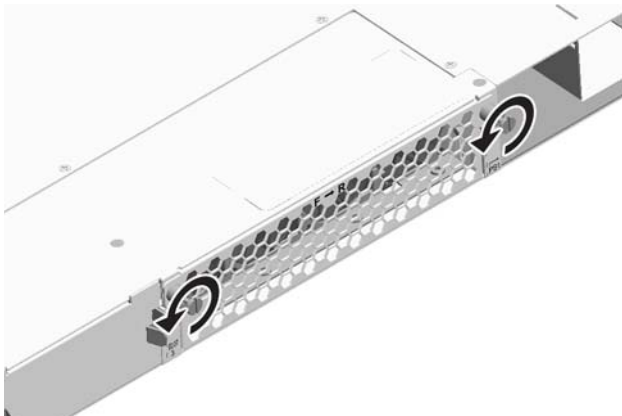

- 2 Pull the fan tray straight out of the chassis.

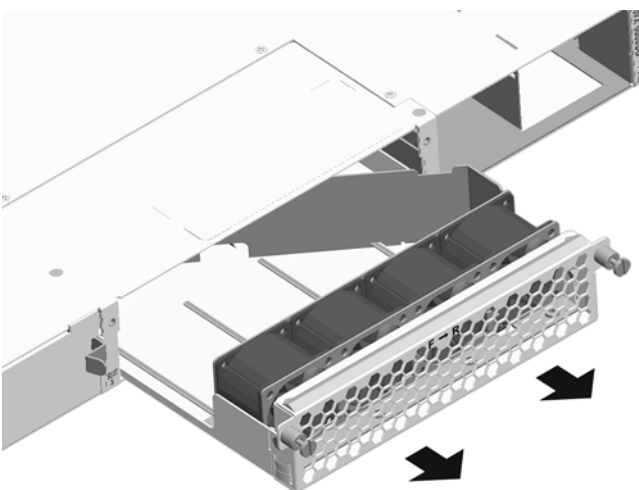

Important. The switch should not run without a fan tray more than 60 seconds to prevent over heating.

Installing the Fan Tray

- 1 Insert the tray into the chassis slot and slide it straight back until it meets the chassis backplane connectors.

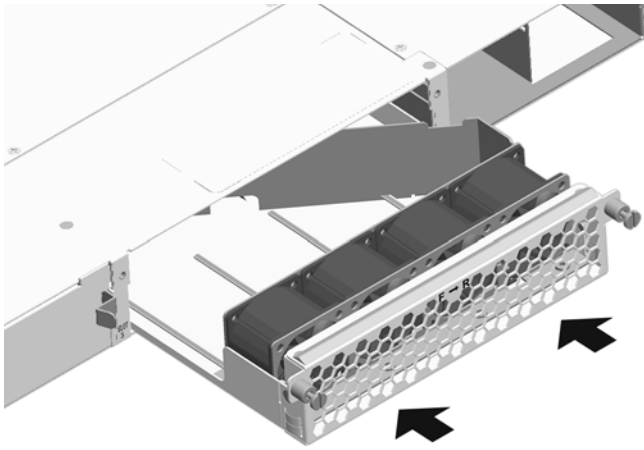

- 2 When the fan tray is firmly seated in the chassis, tighten the two captive screws at the left and right sides of the fan tray's front panel.

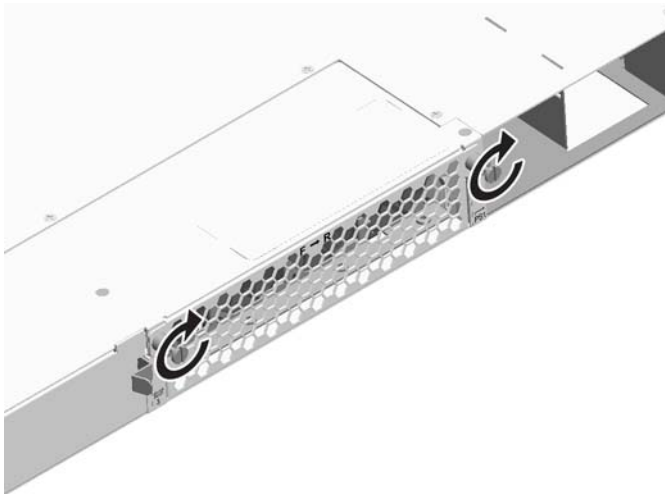

Grounding the Chassis

The switch has a grounding lug located on the rear of the chassis. This lug uses 10-32 screws and is surrounded by a small paint-free area, which provides metal-to-metal contact for a ground connection.

Use this connector to supplement the ground provided by the AC power cord. To do so, install a Panduit Grounding Lug (type LCD8-10A-L) using 8AWG copper conductors to the paint-free area.

Refer to the rear chassis views on [page 2-2](#) for location details.

Monitoring Chassis Components

Viewing Chassis Slot Information

To view basic slot information, enter the show module command at the CLI prompt:

```
-> show module
```

To view more detailed information, use the show module long command:

```
-> show module long
```

Monitoring Chassis Temperature

The operating temperature of your switch is a critical factor in its overall operability. In order to avoid a temperature-related system failure, your switch must always run at a temperature within the specified operating temperature range. Refer to [page 2-4](#) (OS6900-X20 and OS6900-X40) and [page 2-8](#) (OS6900-T20 and OS6900-T40) for more information.

To avoid chassis over-temperature conditions, follow the important chassis airflow recommendations on [page 2-21](#).

To check the switch's current temperature status, use the **show fantray** command. For example:

```
-> show temperature
```

For more information about this command, see the “Chassis Management and Monitoring Commands” chapter in the *OmniSwitch CLI Reference Guide*.

Temperature Errors

The switch monitors the ambient air temperature at all times via an onboard sensor. If an over-temperature condition occurs, there are two different levels of error severity:

- Warning threshold has been exceeded
- Danger threshold has been exceeded

Warning Threshold

If the temperature exceeds the switch's user-configurable warning threshold, the switch sends out a trap. Traps are printed to the console in the form of text error messages.

When the warning threshold has been exceeded, switch operations remain active. However, it is recommended that immediate steps be taken to address the over-temperature condition.

Addressing warning threshold temperature conditions may include:

- Checking for a chassis airflow obstruction
- Checking the ambient room temperature
- Checking the fan tray status using the **show fan** command. See page [page 2-45](#) for more information.
- Verifying that the warning threshold has not been manually set too low.

Note. For the OS6900's default warning threshold value, refer to the specifications on [page 2-2](#). The default value may be configured using the **temp-threshold** command; the currently-configured warning threshold may be viewed using the **show fantray** command.

Temperature Danger Threshold

If the chassis ambient air temperature rises above the danger threshold (see specifications on [page 2-2](#)) the switch will power off until the temperature conditions have been addressed and the switch is manually booted. The danger threshold is factory-set and cannot be configured by the user.

Addressing danger threshold temperature conditions may include:

- Checking for a chassis airflow obstruction or direction mismatch.
- Checking the ambient room temperature
- Checking the fan tray status using the **show fan** command. See page [page 2-45](#) for more information.

Monitoring Fan Tray Status

The switch constantly monitors fan operation. If any of the switch's fans unexpectedly shuts down, the switch sends out a trap and the FAN LED on the chassis front panel displays amber.

To check the switch's current fan tray status, use the **show fan** command. For example:

```
-> show fan
```

For more information about this command, see the "Chassis Management and Monitoring Commands" chapter in the *OmniSwitch CLI Reference Guide*.

A Regulatory Compliance and Safety Information

This appendix provides information on regulatory agency compliance and safety for OmniSwitch 6900 switches.

Declaration of Conformity: CE Mark

This equipment is in compliance with the essential requirements and other provisions of Directive 2004/108/EC (EMC), 2006/95/EC (LVD), 91/263/EEC (Telecom Terminal Equipment, if applicable), 1999/5/EC (R&TTE, if applicable).

Français: Cet équipement est conforme aux exigences essentielles et aux autres provisions de la Directive 2004/108/EC (EMC), 2006/95/CE (LVD), 91/263/CEE (équipements terminaux de télécommunications, le cas échéant), 1999/5/EC (R&TTE, le cas échéant).

Deutsch: Diese Ausrüstung erfüllt die wesentlichen Anforderungen und sonstigen Bestimmungen der Richtlinien 2004/108/EG (EMV-Richtlinie), 2006/95/EG (Niederspannungsrichtlinie), 91/263/EWG (Telekommunikationsendeinrichtungen, falls zutreffend), 1999/5/EG (Funkanlagen und Telekommunikationsendeinrichtungen, falls zutreffend).

Español: Este equipo cumple los requisitos esenciales y otras disposiciones de las directivas 2004/108/CE (EMC), 2006/95/CE (LVD), 91/263/CEE (equipos terminales de telecomunicación, si procede), 1999/5/CE (R&TTE, si procede).

Waste Electrical and Electronic Equipment (WEEE) Statement

The product at end of life is subject to separate collection and treatment in the EU Member States, Norway and Switzerland and therefore marked with the following symbol:

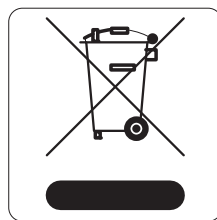

Treatment applied at end of life of the product in these countries shall comply with the applicable national laws implementing directive 2002/96/EC on waste electrical and electronic equipment (WEEE).

China RoHS: Hazardous Substance Table

产品说明书附件

SUPPLEMENT TO PRODUCT INSTRUCTIONS

这个文件涉及的是在中华人民共和国境内进口或销售的电子信息产品
**Include this document with all Electronic Information Products imported
 or sold in the People's Republic of China**

部件名称 (Parts)	有毒有害物质或元素 (Hazardous Substance)					
	铅 (Pb)	汞 (Hg)	镉 (Cd)	六价铬 (Cr ⁶⁺)	多溴联苯 (PBB)	多溴二苯醚 (PBDE)
电路模块 (Circuit Modules)	×	○	○	○	○	○
电缆及电缆组件 (Cables & Cable Assemblies)	×	○	○	○	○	○
金属部件 (Metal Parts)	×	○	○	○	○	○
塑料和聚合物部件 (Plastic and Polymeric parts)	○	○	○	○	○	○
对于交付时集成了电池的电子信息产品 For electronic information products delivered with integrated functional batteries:						
电池 (Batteries)	○	○	○	○	○	○
<p>○： 表示该有毒有害物质在该部件所有均质材料中的含量均在 SJ/T11363-2006 标准规定的限量要求以下。 Indicates that the concentration of the hazardous substance in all homogeneous materials in the parts is below the relevant threshold of the SJ/T11363-2006 standard.</p> <p>×： 表示该有毒有害物质至少在该部件的某一均质材料中的含量超出SJ/T11363-2006标准规定的限量要求。 Indicates that the concentration of the hazardous substance of at least one of all homogeneous materials in the parts is above the relevant threshold of the SJ/T11363-2006 standard.</p> <p>对销售之日的所售产品, 本表显示, 阿尔卡特朗讯公司供应链的电子信息产品可能包含这些物质。注意: 在所售产品中可能会也可能不会含有所有所列的部件。 This table shows where these substances may be found in the supply chain of Alcatel-Lucent electronic information products, as of the date of sale of the enclosed product. Note that some of the component types listed above may or may not be a part of the enclosed product.</p>						

除非另外特别的标注, 此标志为针对所涉及产品的环保使用期标志。某些零部件会有一个不同的环保使用期(例如, 电池单元模块)贴在其产品上。
 此环保使用期限只适用于产品是在产品手册中所规定的条件下工作。
 The Environment-Friendly Use Period (EFUP) for all enclosed products and their parts are per the symbol shown here, unless otherwise marked. Certain parts may have a different EFUP (for example, battery modules) and so are marked to reflect such. The Environment-Friendly Use Period is valid only when the product is operated under the conditions defined in the product manual.



Products are packaged using one or more of the following packaging materials:

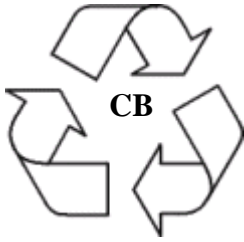

Corrugated Cardboard

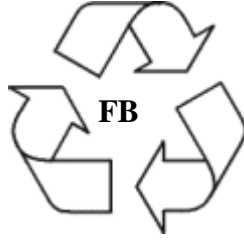

Corrugated Fiberboard



Low-Density Polyethylene

Standards Compliance

The product bears the CE mark. In addition it is in compliance with the following other safety and EMC standards:

All hardware switching modules used in an OmniSwitch 6900 switch comply with Class A standards. Modules with copper connectors meet Class A requirements using unshielded (UTP) cables.

Safety Standards

- UL 60950-1, 2nd Edition
- CAN/CSA-C22.2 No. 60950-1-07, 2nd Edition
- EN 60950-1 with Amendment II
- IEC 60950-1 2nd Edition
- AS/NZS TS-001 and 60950: Australia
- UL-AR, Argentina
- TUV,UL-GS Mark, Germany
- NOM-019 SCFI, Mexico
- EN 60825-1 Laser
- EN 60825-2 Laser
- CDRH Laser
- CB Certification per IEC 60950-1, Second Edition)

EMC Standards

- FCC Part 15 (CFR 47) Class A
- ICES-003 Class A
- EN 55022: Class A
- CISPR 22 Class A
- AS/NZS 3548 Class A
- VCCI Class A; A1 and A2
- EN 55024: (Immunity)
- EN 61000-3-2
- EN 61000-3-3
- EN 61000-4-2
- EN 61000-4-3
- EN 61000-4-4
- EN 61000-4-5
- EN 61000-4-6
- EN 61000-4-8
- EN 61000-4-11

Environmental Standards

- ETS 300 019 Storage Class 1.1
- ETS 300 019 Transportation Class 2.3
- ETS 300 019 Stationary Use Class 3.1

FCC Class A, Part 15

This equipment has been tested and found to comply with the limits for Class A digital device pursuant to Part 15 of the FCC Rules. These limits are designed to provide reasonable protection against harmful interference when the equipment is operated in a commercial environment. This equipment generates, uses, and can radiate radio frequency energy and, if not installed and used in accordance with the instructions in this guide, may cause interference to radio communications. Operation of this equipment in a residential area is likely to cause interference, in which case the user will be required to correct the interference at his own expense.

The user is cautioned that changes and modifications made to the equipment without approval of the manufacturer could void the user's authority to operate this equipment. It is suggested that the user use only shielded and grounded cables to ensure compliance with FCC Rules.

If this equipment does cause interference to radio or television reception, the user is encouraged to try to correct the interference by one or more of the following measures:

- Reorient the receiving antenna.
- Relocate the equipment with respect to the receiver.
- Move the equipment away from the receiver.
- Plug the equipment into a different outlet so that equipment and receiver are on different branch circuits.

If necessary, the user should consult the dealer or an experienced radio/television technician for additional suggestions.

Canada Class A Statement

This equipment does not exceed Class A limits per radio noise emissions for digital apparatus, set out in the Radio Interference Regulation of the Canadian Department of Communications.

Avis de conformité aux normes du ministère des Communications du Canada

Cet équipement ne dépasse pas les limites de Classe A d'émission de bruits radioélectriques pour les appareils numériques, telles que prescrites par le Règlement sur le brouillage radioélectrique établi par le ministère des Communications du Canada.

JATE

This equipment meets the requirements of the Japan Approvals Institute of Telecommunications Equipment (JATE).

CISPR22 Class A warning

This is a Class A product. In a domestic environment, this product may cause radio interference. Under such circumstances, the user may be requested to take appropriate countermeasures.

Korea Emissions Statement

A 급 기기 (업무용 방송통신 기자재)

이 기기는 업무용 (A 급) 전자파적합기기로서 판매자 또는 사용자는 이 점을 주의하시기 바라며, 가정외의 지역에서 사용하는 것을 목적으로 합니다.

Class A Equipment (Business equipment)

This equipment is registered for Electromagnetic Conformity Registration as business equipment (A), not home equipment. Sellers or users are required to take caution in this regard.

VCCI

This is a Class A product based on the standard of the Voluntary Control Council for Interference by Information Technology Equipment (VCCI). If this equipment is used in a domestic environment, radio disturbance may arise. When such trouble occurs, the user may be required to take corrective actions.

この装置は、情報処理装置等電波障害自主規制協議会（VCCI）の基準に基づくクラスA情報技術装置です。この装置を家庭環境で使用すると電波妨害を引き起こすことがあります。この場合には使用者が適切な対策を講ずるよう要求されることがあります。

Class A Warning for Taiwan and Other Chinese Markets

This is a Class A Information Product. When used in a residential environment, it may cause radio frequency interference. Under such circumstances, the user may be requested to take appropriate countermeasure.

警告使用者：

這是甲類的資訊產品，在居住的環境中使用時，可能會造成射頻干擾，在這種情況下，使用者會被要求採取某些適當的對策。

Class 1M Laser Warning

CLASS 1M LASER RADIATION WHEN OPEN. DO NOT VIEW DIRECTLY WITH OPTICAL INSTRUMENTS.

Network Cable Installation Warning

Never install exposed network cables outdoors. Install network cables per manufacturer requirements.

Translated Safety Warnings

Blank Panels Warning

Because they regulate airflow and help protect internal chassis components, blank cover plates should remain installed at empty module slots and power supply bays at all times.

Français: Les caches blancs remplissent trois fonctions importantes: ils évitent tout risque de choc électrique à l'intérieur du châssis, ils font barrage aux interférences électromagnétiques susceptibles d'altérer le fonctionnement des autres équipements et ils dirigent le flux d'air de refroidissement dans le châssis. Il est vivement recommandé de vérifier que tous les caches, modules d'alimentation et plaques de protection sont en place avant d'utiliser le système.

Deutsch: Die leeren Modulblenden schützen interne Komponenten und leiten den Luftstrom. Deshalb müssen in allen unbelegten Slots die Modulblenden immer installiert bleiben.

Español: Las tapaderas blancas regulan la circulación de aire y ayudan a proteger componentes internos del chasis y siempre deben estar instaladas en las ranuras vacías del chasis y fuentes de alimentación.

Electrical Storm Warning

To avoid a shock hazard, do not connect or disconnect any cables or perform installation, maintenance, or reconfiguration of this product during an electrical storm.

Français: Ne pas travailler sur le système ni brancher ou débrancher les câbles pendant un orage.

Deutsch: Um elektrische Schläge zu vermeiden dürfen während eines Gewitters and diesem Gerät keine Kabel angeschlossen oder gelöst werden, sowie keinerlei Installationen, Wartungen oder Konfigurationen vorgenommen werden.

Español: Para evitar peligro de descargas, no conecte o desconecte ningún cable, ni realice ninguna instalación, mantenimiento o reconfiguración de este producto durante una tormenta eléctrica.

Installation Warning

Only personnel knowledgeable in basic electrical and mechanical procedures should install or maintain this equipment.

Français: Toute installation ou remplacement de l'appareil doit être réalisée par du personnel qualifié et compétent.

Deutsch: Dieses Gerät soll nur von Personal installiert oder gewartet werden, welches in elektrischen und mechanischen Grundlagen ausgebildet ist.

Español: Estos equipos deben ser instalados y atendidos exclusivamente por personal adecuadamente formado y capacitado en técnicas eléctricas y mecánicas.

Invisible Laser Radiation Warning

Lasers emit invisible radiation from the aperture opening when no fiber-optic cable is connected. When removing cables do not stare into the open apertures. In addition, install protective aperture covers to fiber ports with no cable connected.

Français: Des radiations invisibles à l'œil nu pouvant traverser l'ouverture du port lorsque aucun câble en fibre optique n'y est connecté, il est recommandé de ne pas regarder fixement l'intérieur de ces ouvertures. Installez les caches connecteurs prévus à cet effet.

Deutsch: Die Laser strahlen an der Blendenöffnung unsichtbares Licht ab, wenn keine Glasfaserkabel angeschlossen sind. Blicken Sie nicht in die Öffnungen und installieren Sie unverzüglich die Abdeckungen über den Glasfaseranschlüssen.

Español: Debido a que la apertura del puerto puede emitir radiación invisible cuando no hay un cable de fibra conectado, procurar no mirar directamente a las aperturas para no exponerse a la radiación.

Operating Voltage Warning

To reduce the risk of electrical shock, keep your hands and fingers out of power supply bays and do not touch the backplane while the switch is operating.

Français: Pour réduire tout risque électrique, gardez vos mains et doigts hors des alimentations et ne touchez pas au fond de panier pendant que le commutateur fonctionne.

Deutsch: Um die Gefahr des elektrischen Schlages zu verringern, greifen sie bitte nicht in die Spannungsversorgung und berühren sie nicht die Rückwandplatine während das Gerät arbeitet.

Español: Para reducir el riesgo de descargas eléctricas, no meta sus manos y dedos dentro del chasis de la fuente de alimentación y no toque componentes internos mientras que el interruptor está conectado.

Power Disconnection Warning

Your switch is equipped with multiple power supplies. To reduce the risk of electrical shock, be sure to disconnect all power connections before servicing or moving the unit.

Français: Il se peut que cette unité soit équipée de plusieurs raccordements d'alimentation. Pour supprimer tout courant électrique de l'unité, tous les cordons d'alimentation doivent être débranchés.

Deutsch: Ihr Gerät ist mit mehreren Netzteilen ausgerüstet. Um die Gefahr des elektrischen Schlages zu verringern, stellen sie sicher, daß alle Netzverbindungen getrennt sind bevor das Gerät gewartet oder bewegt wird.

Español: Antes de empezar a trabajar con un sistema, asegurese que el interruptor está cerrado y el cable eléctrico desconectado.

Proper Earthing Requirement Warning

To avoid shock hazard:

- The power cord must be connected to a properly wired and earth receptacle.
- Any equipment to which this product will attached must also be connected to properly wired receptacles.

Français:

Pour éviter tout risque de choc électrique:

- Ne jamais rendre inopérant le conducteur de masse ni utiliser l'équipement sans un conducteur de masse adéquatement installé.
- En cas de doute sur la mise à la masse appropriée disponible, s'adresser à l'organisme responsable de la sécurité électrique ou à un électricien.

Deutsch:

Aus Sicherheitsgründen:

- darf das Netzkabel nur an eine Schutzkontaktsteckdose angeschlossen werden.
- dürfen für den Anschluß anderer Geräte, welche mit diesem Gerät verbunden sind, auch nur Schutzkontaktsteckdosen verwendet werden.

Español:

Para evitar peligro de descargas:

- Para evitar peligro de descargas asegurese de que el cable de alimentación está conectado a una toma de alimentación adecuadamente cableada y con toma de tierra.
- Cualquier otro equipo a cual se conecte este producto también debe estar conectado a tomas de alimentación adecuadamente cableadas.

DC Power Supply Connection Warning

For EMC/EMI, each DC/DC power supply requires that the ground wire is connected from each DC/DC power supply to Common Earth Ground.

Français: Pour EMC/EMI, pour chaque alimentation DC/DC, il est impératif que le fil de terre soit branché à la prise de terre commune.

Deutsch: Zur Erfüllung der EMV-/EMI-Anforderungen muss das Erdungskabel jedes DC/DC-Netzteils an eine gemeinsame Erde angeschlossen werden.

Español: Para EMC/EMI, cada fuente de alimentación de CC/CC requiere que el cable de tierra esté conectado desde cada fuente de alimentación de CC/CC a la conexión a tierra común.

Read Important Safety Information Warning

The *Getting Started Guide* that accompanied this equipment contains important safety information about which you should be aware when working with hardware components in this system. You should read this guide before installing, using, or servicing this equipment.

Français: Avant de brancher le système sur la source d'alimentation, consultez les directives d'installation disponibles dans le "Getting Started Guide".

Deutsch: Der Getting Started Guide, welcher diese Anlage beiliegt, enthält wichtige Sicherheitsinformationen, über die sie sich beim Arbeiten mit den Hardwareeinheiten bewußt sein sollten. Sie sollten diese Hinweise lesen, bevor sie installieren, reparieren oder die Anlage verwenden.

Español: La 'Getting Started Guide' que acompañó este equipo contiene información importante de seguridad sobre la cual usted debe estar enterado al trabajar con los componentes de dotación física en este sistema. Usted debe leer esta guía antes de instalar, usar o mantener este equipo.

Restricted Access Location Warning

This equipment should be installed in a location that restricts access. A restricted access location is one where access is secure and limited to service personnel who have a special key, or other means of security.

Français: Le matériel doit être installé dans un local avec accès limité ou seules les personnes habilitées peuvent entrer.

Deutsch: Die Anlage sollte an einem Standort mit beschränktem Zutritt installiert sein. Ein Standort mit beschränktem Zutritt stellt sicher, daß dort nur Servicepersonal mit Hilfe eines Schlüssels oder eines anderen Sicherheitssystems Zugang hat.

Español: Este equipo se debe instalar en un sitio con acceso restringido. Un sitio con el acceso restringido es uno seguro y con acceso limitado al personal de servicio que tiene una clave especial u otros medios de seguridad.

Wrist Strap Warning

Because electrostatic discharge (ESD) can damage switch components, you must follow proper procedures to eliminate ESD from your person and the surrounding area before handling switch components.

Français: Parce que les décharges électrostatiques (ESD) peuvent endommager les composants de commutation, vous devez suivre les procédures appropriées pour éliminer ESD de votre personne et la région environnante avant de manipuler les composants de commutation.

Deutsch: Da elektrostatische Entladung (ESD) Switch-Komponenten beschädigen können, müssen Sie geeignete Verfahren zur Beseitigung von Ihrer Person und die Umgebung vor dem Umgang mit ESD-Schalter-Komponenten.

Español: Debido a las descargas electrostáticas (ESD) puede dañar los componentes del interruptor, debe seguir los procedimientos adecuados para eliminar la ESD de su persona y sus alrededores antes de manipular los componentes del interruptor.

Instrucciones de seguridad en español

Advertencia sobre el levantamiento del chasis

Se requieren dos personas para levantar el chasis. Debido a su peso, la elevación del chasis sin ayuda puede causar daños corporales. También es seguro doblar sus rodillas y guardar su espalda derecho al ayudar a levantar el chasis.

Advertencia de las tapaderas en blanco

Porque regulan la circulación de aire y ayudan a proteger componentes internos del chasis, las tapaderas en blanco deben seguir instaladas en las ranuras vacías del módulo y la fuente de alimentación siempre.

Advertencia en caso de tormenta eléctrica

Para evitar peligro de descargas, no conecte o desconecte ningún cable, ni realice ninguna instalación, mantenimiento o reconfiguración de este producto durante una tormenta eléctrica.

Advertencia de instalación

Solamente el personal bien informado en procedimientos eléctricos y mecánicos básicos debe instalar o mantener este equipo.

Advertencia de radiación láser invisible

Los lasers emiten radiación invisible de la apertura abierta cuando no se conecta ningún cable de fibra óptica. Al quitar los cables no mire fijamente en las aberturas abiertas. Además, instale las cubiertas protectoras de la apertura a las salidas de la fibra sin el cable conectado.

Advertencia de la batería de litio

Hay un peligro de la explosión si la batería del litio en su chasis se substituye incorrectamente. Substituya la batería solamente por el mismo o el equivalente de tipo de batería recomendado por el fabricante. Deseche las baterías usadas según las instrucciones del fabricante. Las instrucciones del fabricante son como sigue: Devuelva el módulo con la batería del litio a Alcatel-Lucent. La batería del litio será substituida en la fábrica de Alcatel-Lucent.

Advertencia sobre la tensión de operación

Para reducir el riesgo del choque eléctrico, mantenga sus manos y dedos fuera de la fuente de alimentación y no toque la placa madre mientras que el interruptor está funcionando.

Advertencia sobre la desconexión de la fuente

Su interruptor esta equipado por fuentes de alimentación múltiples. Para reducir el riesgo de choque eléctrico, asegúrese desconectar todas las conexiones de alimentación antes de mantener o de mover la unidad.

Advertencia sobre una apropiada conexión a tierra

Para evitar peligro de descargas:

- El cable de alimentación debe estar conectado a una toma de alimentación adecuadamente cableada y con toma de tierra.

Cualquier equipo al cual se conecte este producto debe estar también conectado a tomas de alimentación adecuadamente cableadas.

Leer “información importante de seguridad”

La *Guía de “Comenzando a Usar”* que acompaña este equipo contiene información importante de seguridad sobre la cual usted debe saber al trabajar con los componentes de dotación física en este sistema. Usted debe leer esta guía antes de instalar, de usar, o de mantener este equipo.

Advertencia de acceso restringido

Este equipo se debe instalar en una ubicación que restrinja el acceso. Una ubicación con acceso restringido es una donde está seguro y limitado el acceso al personal de servicio que tiene un clave especial, u otros medios de la seguridad.

Advertencia de pulsera antiestática

Debido a que la descarga electrostática (ESD) puede dañar componentes del interruptor, usted debe conectarse a tierra correctamente antes de continuar con la instalación del equipo. Para este propósito, Alcatel-Lucent proporciona una pulsera antiestática y un terminal que pone a tierra situados cerca de la parte superior derecha del chasis. Para que la pulsera antiestática sea eficaz en la eliminación de ESD, las fuentes de alimentación se deben instalar en el chasis y enchufar en las salidas de CA con descarga a tierra.

Clase de seguridad

Cumple con 21CFR 1040.10 y 1040.11 ó sus equivalentes.

Advertencia de fuentes de poder

Las unidades OmniSwitch 6900 pueden estar equipadas con tres cordones para fuente de poder. Para reducir el riesgo de un choque eléctrico, desconecte todos los cordones de fuente de poder antes de dar servicio a la unidad.